

PARTS LIST

Fx15

HYDRAULIC BREAKER

APPLICABLE SERIAL NUMBER 1001 AND UP



SUPPLY PERIOD OF SPARE PARTS

Thank you for purchasing a Furukawa Rock Drill product.

Please note that the supply of spare parts will be assured for 10 years after the termination of production in accordance with the guidelines for the supply of spare parts as specified by the Japan Construction Equipment Manufacturers Association.

Although the supply of spare parts is terminated in principle at the maturity of the subject supply period, we may be able to supply them upon request even after the expiration of the supply period on condition that the delivery date and price are subject to negotiation.

Even if it is within the supply period, however, the delivery date, price, etc. may be subject to negotiation when it is difficult to keep stocks should the purchased parts, such as electronic parts, etc., be not available because the manufacturer does not produce them any more.

If you have any questions about any particular model subject to the warranty as stated above and the time limit of spare parts supply, please contact your nearest FRD Europe B.V. distributor.

USING THE PARTS LIST

1. This parts list describes the components of a hydraulic breaker.
2. When ordering a part, refer to the illustrations and lists in this parts list and then inform the FRD Europe B.V. distributor in your area of the following items.
 - (1) Model name
 - (2) Serial No.
 - (3) Part No.
 - (4) Part name
 - (5) Quantity
3. Use "Genuine Furukawa Rock Drill Parts" when replacing all parts.
4. The illustrations in this parts list show the positions and shapes of the parts so that a user can order a part without any problem.
Do not repair a hydraulic breaker by using this parts list.
5. The parts in this list are subject to change for improvement without notice on the part of the manufacturer.

How to use the parts list

(1) Illustration

- ① Group NameThis is the same as the Group Name on the CONTENTS.
- ② Fig. No.....This shows the illustration number and corresponds to Fig. No. of the parts breakdown.
- ③ ItemThis corresponds to Item in the parts breakdown.
- ④ Group NameThis shows the group name in which the parts breakdown is covered in a separate page in this parts list.
- ⑤ Page.....The left side of “ - ” (hyphen) shows consecutive numbers in each unit. The right side shows consecutive numbers of drawings/lists in each unit.

(2) Parts Breakdown

- ① ItemThis is shown by three figures and corresponds to Item in the illustration. Item nos. are not always in sequence.
When a part has been changed in design and then the part number or quantity has been changed, a sub-number is added to Item in order to show the order of change.
- ② Part No.....(a) Part number is shown.
(b) Indication of a no-service part
With parts which cannot be serviced as a single part, only the illustrations and part names are given and the mark * is shown in the part number column. These parts are serviced as an assembly, a kit or a set.
- ③ Part Name.....This shows the description of a part. When following marks are put before the part name:
No mark..... Represents a single part or an assembly component.
*..... Represents a part or an assembled part of the assembly component. It is listed out after the assembly name.
**..... Represents a part of the assembled part of the assembly component.
- ④ Q' tyAs a rule, this column indicates the quantity of a part required for one breaker. In case of a part of an assembly component, however, it indicates the quantity of the part required for one assembly component. In this column, the following mark is also used besides the numerals to indicate the quantity of parts.
()Parenthesis..... This part does not include an assembly. · · · Option etc.
AR As required.

⑥ Serial No. Serial No. in which this part is used is as shown in the following example:

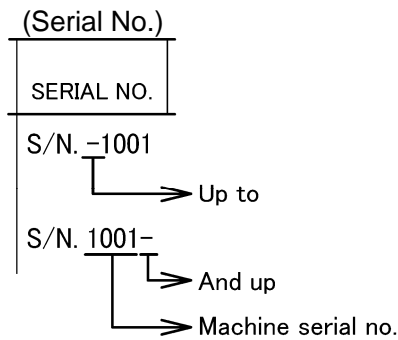

⑥ Remarks The marks and part numbers in the Remarks column are described below.

A Replaceable common part and following part no.

B Represents that this part is not supplied as a single part, however, it is supplied as a set.
Refer to Replaceable Parts List at the end of the parts list.

C Represents that this part is not supplied as a single part.
When an assembly including this part is supplied, the parts after this mark are supplied. When no parts are given after this mark, the components of this part are supplied.

D This part is no longer manufactured due to an incorrect part number or a change and supplying this part is discontinued. When a substitute can be supplied, the part number after this mark is supplied.

⑦ Page The left side of “ - ” (hyphen) shows consecutive numbers in each unit.
The right side shows consecutive numbers of drawings/lists in each unit.

Name of Components or Component Group

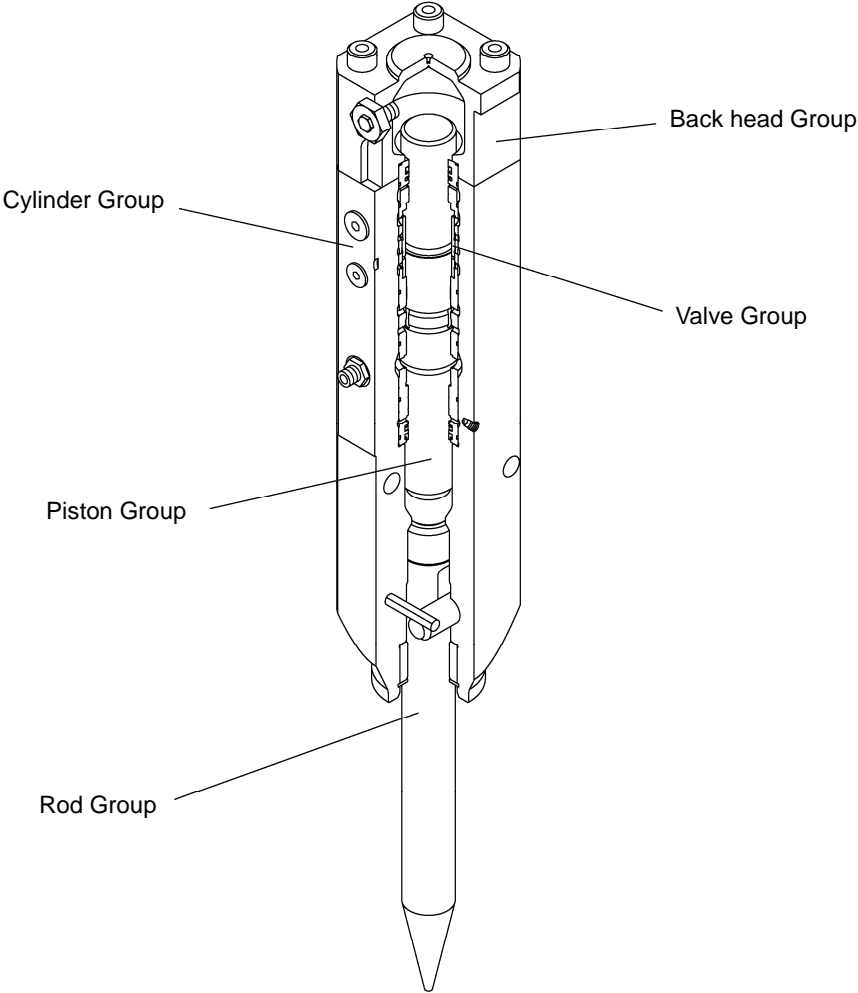

CONTENTS

FIG.NO.	GROUP NAME	PAGE
902305-000010	BREAKER BODY UNIT	01-01
902305-920010	SEAL KIT	02-01
902305-800010	BRACKET	03-01
902305-822010	FLAT TOP BRACKET	04-01
	TOP BRACKET	05-01
	HYDRAULIC HOSE ASSEMBLY	06-01
	STICKERS	07-01
902306-900010	STANDARD TOOLS	08-01
	BACK HEAD PRESSURE CHARGING KIT	09-01

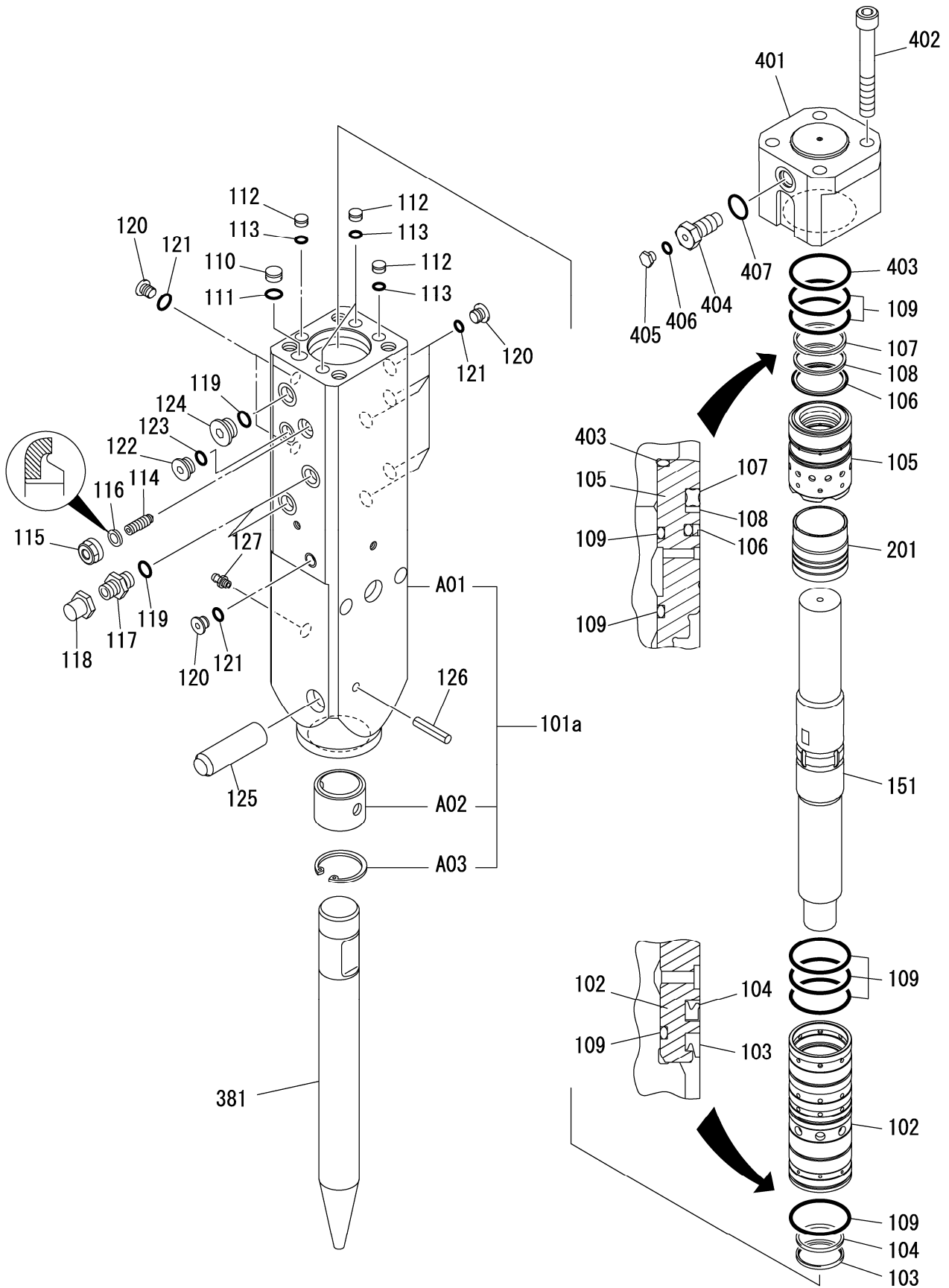

ITEM	PART NO.	PART NAME	Q'TY	REMARKS
101a	002305-100010	CYLINDER	1	
A01	*	*CYLINDER	1	
A02	HB1G-20503	*FRONT BUSH	1	
A03	264020-00050	*SNAP RING	1	
102	002305-100030	CYLINDER LINER	1	
103	HB1R-10106	DUST SEAL	1	R1
104	HB1R-10107	U-PACKING	1	R1
105	002305-100040	SEAL RETAINER	1	
106	002305-100050	STEP SEAL	1	R1
107	002305-100061	QUAD RING	1	R1
108	002305-100070	BACK-UP RING	1	R1
109	161021-00050	O-RING	6	R1
110	HB2R-10120	PLUG	1	R1
111	160011-10010	O-RING	1	R1
112	HB05R-10122	PLUG	4	R1
113	160011-00009	O-RING	4	R1
114	F4-10231	ADJUSTER	1	
115	F4-10233	SEAL NUT	1	
116	HB1G-10532	SEAL WASHER	1	R1
117	084861-03000	MALE CONNECTOR	2	
118	084898-03000	UNION CAP	2	
119	160011-00014	O-RING	3	R1
120	084891-01000	GPF PLUG	8	
121	160011-00008	O-RING	8	R1
122	084891-02000	GPF PLUG	1	
123	160011-00011	O-RING	1	R1
124	084891-03000	GPF PLUG	1	
125	F1-20206	ROD PIN	1	
126	154037-08050	SPRING PIN	1	
127	170312-00000	GREASE NIPPLE	1	
151	002305-110010	PISTON	1	
201	002305-130010	VALVE	1	

ITEM	PART NO.	PART NAME	Q'TY	REMARKS
381	F1-25111	FLAT ROD	1	ALTERNATIVE
381	F1-25113	MOIL POINT	1	ALTERNATIVE
381	F1-25114	WEDGE ROD	1	ALTERNATIVE
381	F1-25115	CONE ROD	1	ALTERNATIVE
401	002305-300010	BACK HEAD	1	
402	102032-14120	SOCKET BOLT	4	
403	161021-00050	O-RING	1	R1
404	HB15G-30103	CHARGING VALVE	1	
405	HB20G-30109	PLUG	1	
406	160011-00006	O-RING	1	R1
407	160011-00018	O-RING	1	R1

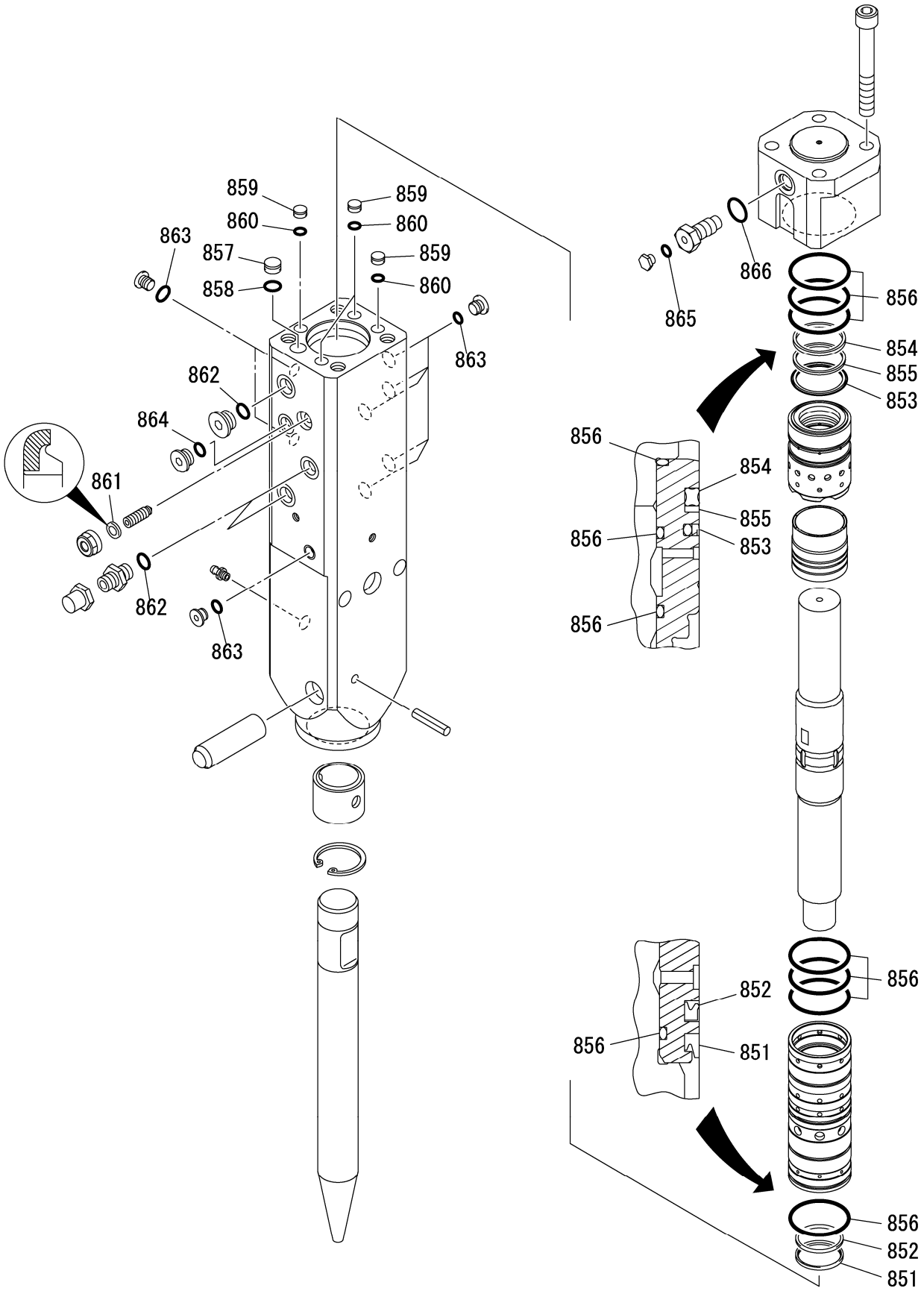

ITEM	PART NO.	PART NAME	Q'TY	REMARKS
	902305-920010	SEAL KIT		
851	HB1R-10106	*DUST SEAL	1	
852	HB1R-10107	*U-PACKING	1	
853	002305-100050	*STEP SEAL	1	
854	002305-100061	*QUAD RING	1	
855	002305-100070	*BACK-UP RING	1	
856	161021-00050	*O-RING	7	
857	HB2R-10120	*PLUG	1	
858	160011-10010	*O-RING	1	
859	HB05R-10122	*PLUG	4	
860	160011-00009	*O-RING	4	
861	HB1G-10532	*SEAL WASHER	1	
862	160011-00014	*O-RING	3	
863	160011-00008	*O-RING	8	
864	160011-00011	*O-RING	1	
865	160011-00006	*O-RING	1	
866	160011-00018	*O-RING	1	

Dimension	A	B	C	D
Part No.				
902305-800010	φ 45 mm	130 mm	180 mm	144 mm

D: Distance between pins

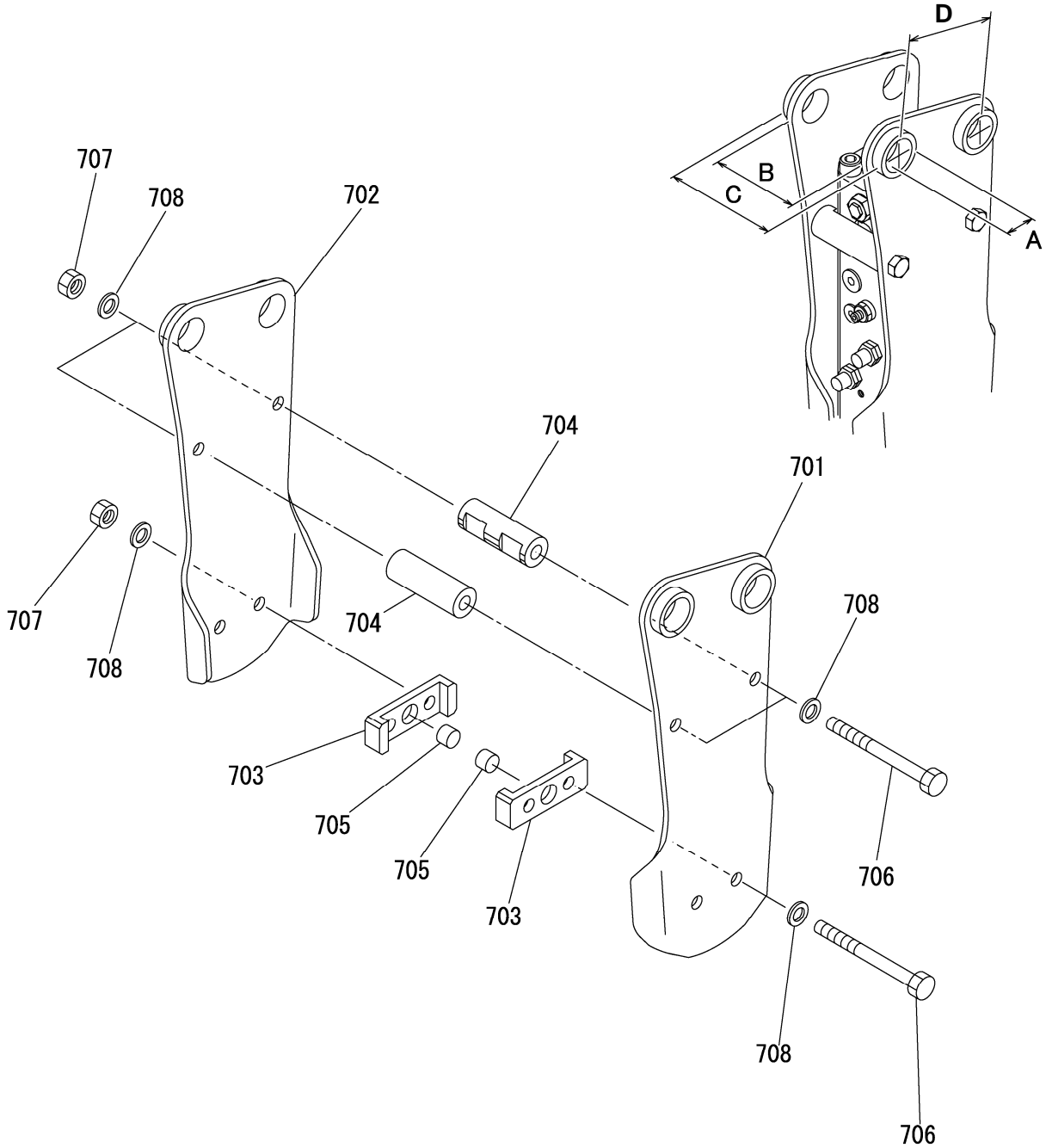

ITEM	PART NO.	PART NAME	Q'TY	REMARKS
	902305-800010	BRACKET ASSEMBLY		
701	002305-800010	*BRACKET (R)	1	
702	002305-800020	*BRACKET (L)	1	
703	002305-810020	*SET PLATE	2	
704	002305-810030	*DISTANCE PIPE	2	
705	002305-810040	*SET PIN	2	
706	101032-16170	*BOLT	4	
707	120132-16000	*NUT	4	
708	HB1R-81114E	*NORD-LOCK WASHER	8	

Top bracket mounting dimensions:

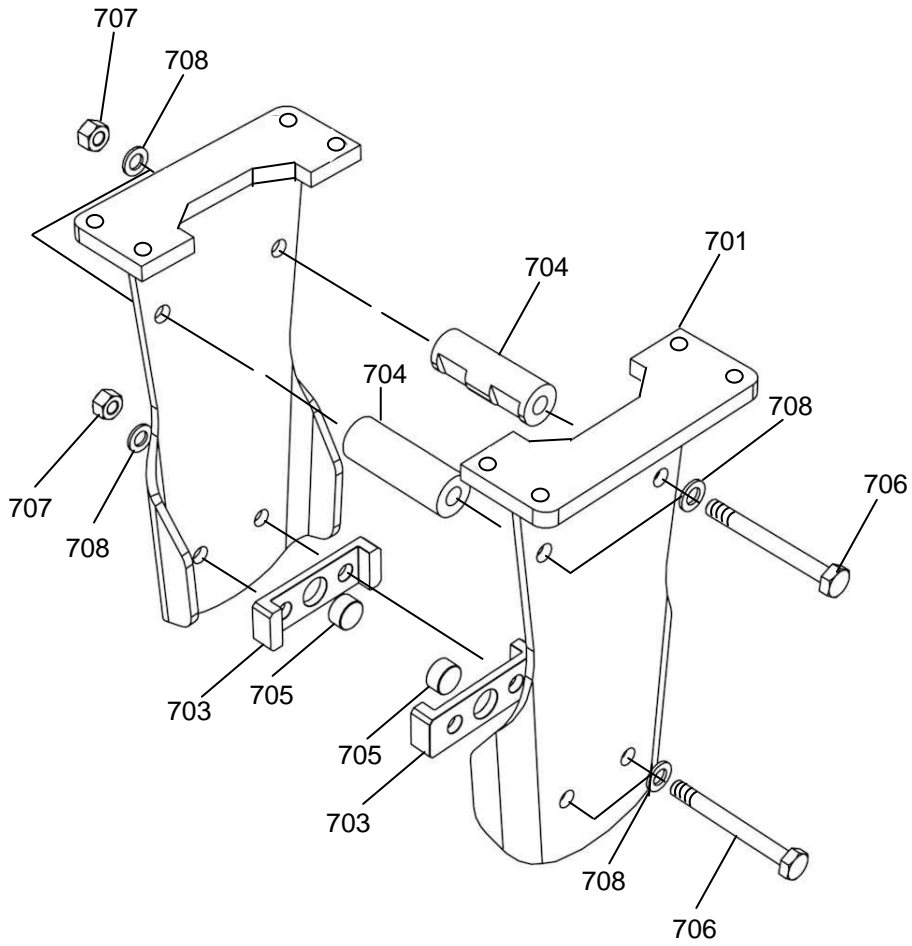
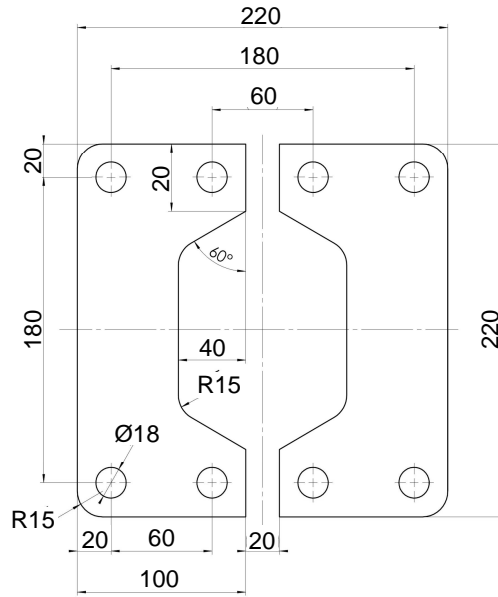

ITEM	PART NO.	PART NAME	Q'TY	REMARKS
	902305-822010	BRACKET ASSEMBLY		
701	002305-822010	*BRACKET (R)	1	
702	002305-822020	*BRACKET (L)	1	
703	002305-810020	*SET PLATE	2	
704	002305-810030	*DISTANCE PIPE	2	
705	002305-810040	*SET PIN	2	
706	101032-16170	*BOLT	4	
707	120132-16000	*NUT	4	
708	HB1R-81114E	*NORD-LOCK WASHER	8	

TOP BRACKET

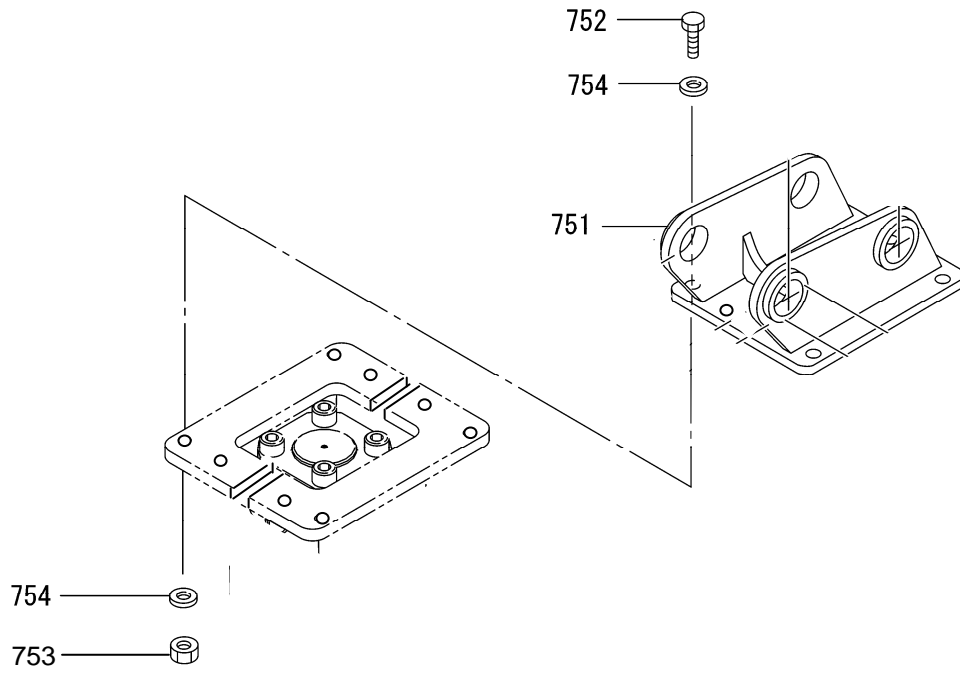

ITEM	PART NO.	PART NAME	Q'TY	REMARKS
751		TOP BRACKET	1	FLAT TOP BRACKET
752	101032-12060	BOLT	8	
753	120132-12000	NUT	8	
754	140112-12000	WASHER	8	

HYDRAULIC HOSE ASSEMBLY

BRACKET AND FLAT TOP BRACKET

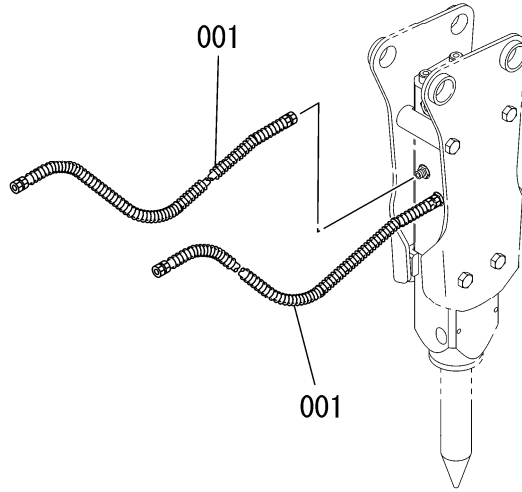

ITEM	PART NO.	PART NAME	Q'TY	REMARKS
001	1003246	HYDRAULIC HOSE ASSEMBLY HYDRAULIC HOSE	2	FOR BRACKET AND FLAT TOP BRACKET

STICKERS

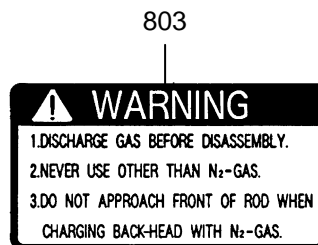
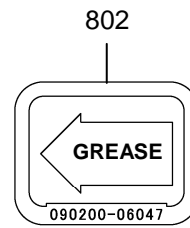
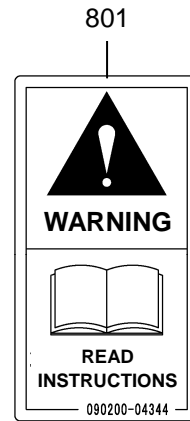
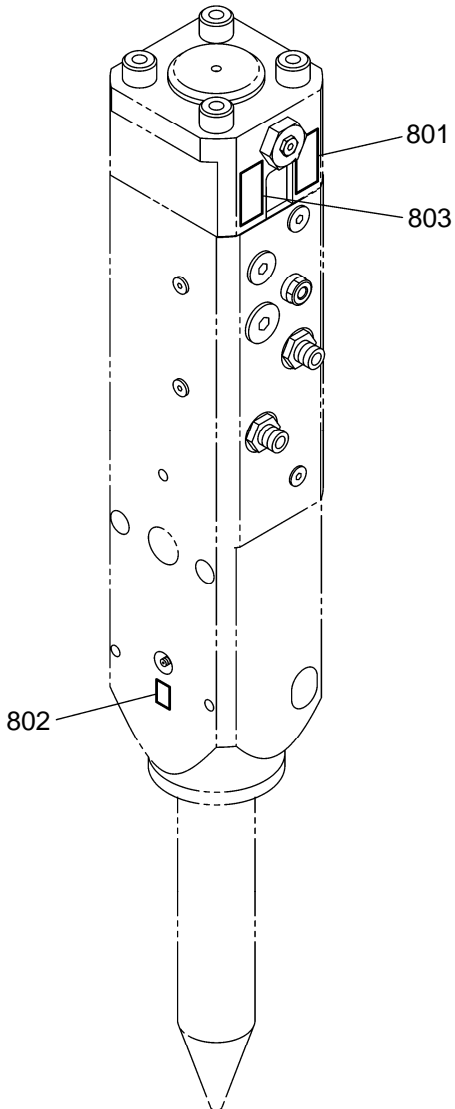

ITEM	PART NO.	PART NAME	Q'TY	REMARKS
801	090200-04344	WARNING STICKER	1	ENGLISH
802	090200-06047	CAUTION STICKER	1	ENGLISH
803	090200-04209	WARNING STICKER	1	ENGLISH FOR STICKERS IN OTHER LANGUAGES PLEASE ASK YOUR NEAREST FRDE DISTRIBUTOR

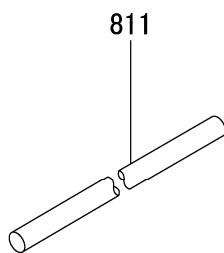
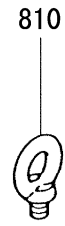
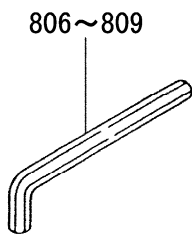
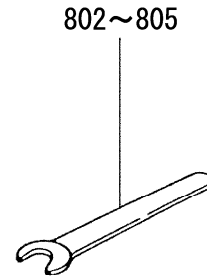
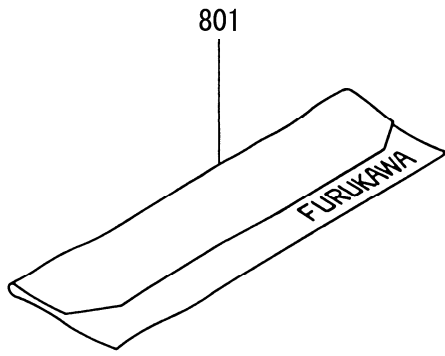

ITEM	PART NO.	PART NAME	Q'TY	REMARKS
801	090012-91012	TOOL CASE	1	
802	090012-11010	14mm SPANNER	1	
803	090012-11014	22mm SPANNER	2	
804	090012-11016	24mm SPANNER	2	
805	090012-11018	27mm SPANNER	1	
806	090012-17006	5mm HEXAGON BAR WRENCH	1	
807	090012-17007	6mm HEXAGON BAR WRENCH	1	
808	090012-17008	8mm HEXAGON BAR WRENCH	1	
809	090012-17010	12mm HEXAGON BAR WRENCH	1	
810	117012-10000	EYE BOLT	2	
811	002305-900010	PRESS PIN	1	
812	HB1G-10532	SEAL WASHER	1	

BACK HEAD PRESSURE CHARGING KIT

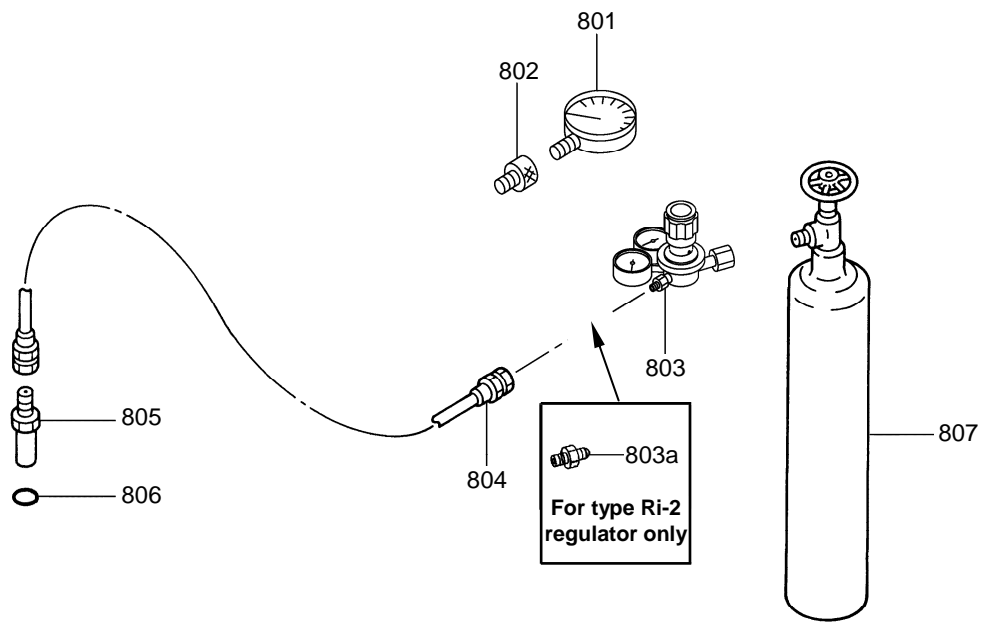

ITEM	PART NO.	PART NAME	Q'TY	REMARKS
801	HB20G-920131 H-11016	BACK HEAD CHARGING KIT *PRESSURE GAUGE	1	FOR: AUSTRIA, BULGARIA, CZECH REP., DENMARK,
802	HB20G-921072	*ADAPTER	1	FINLAND, GERMANY, ICELAND,
803	046012	*REGULATOR (Ru-3)	1	NETHERLANDS, NORWAY,
804	1001766	*CHARGING HOSE	1	POLAND, RUSSIA (MOSCOW),
805	HB20G-921071	*CHARGING ADAPTER	1	SERBIA, SLOVAKIA, SWEDEN,
806	161011-00006	*O-RING	1	SWITZERLAND.
807	-	NITROGEN GAS CYLINDER	1	
801	HB20G-920132 H-11016	BACK HEAD CHARGING KIT *PRESSURE GAUGE	1	FOR: FRANCE, PORTUGAL, ROMANIA, SPAIN.
802	HB20G-921072	*ADAPTER	1	
803	046016	*REGULATOR (B-4)	1	
804	1001766	*CHARGING HOSE	1	
805	HB20G-921071	*CHARGING ADAPTER	1	
806	161011-00006	*O-RING	1	
807	-	NITROGEN GAS CYLINDER	1	
801	HB20G-920133 H-11016	BACK HEAD CHARGING KIT *PRESSURE GAUGE	1	FOR: GREAT BRITAIN, IRELAND MALTA, SOUTH AFRICA.
802	HB20G-921072	*ADAPTER	1	
803	046017	*REGULATOR (Ri-2)	1	
803a	2243-04-06	*CONNECTOR	1	
804	1001766	*CHARGING HOSE	1	
805	HB20G-921071	*CHARGING ADAPTER	1	
806	161011-00006	*O-RING	1	
807	-	NITROGEN GAS CYLINDER	1	
801	HB20G-920134 H-11016	BACK HEAD CHARGING KIT *PRESSURE GAUGE	1	FOR: BELGIUM, CYPRUS, ESTONIA, GREECE, HUNGARY,
802	HB20G-921072	*ADAPTER	1	ISRAEL, ITALY, LATVIA,
803	046018	*REGULATOR (Ru-1)	1	LITHUANIA, RUSSIA (GENERAL)
804	1001766	*CHARGING HOSE	1	UKRAINE.
805	HB20G-921071	*CHARGING ADAPTER	1	
806	161011-00006	*O-RING	1	
807	-	NITROGEN GAS CYLINDER	1	

FRD FURUKAWA ROCK DRILL CO.,LTD.
FURUKAWA

1-5-3, Nihonbashi, Chuo-ku,
Tokyo, 103-0027, Japan.
Phone:81-3-3231-6982 Fax:81-3-3231-6993

European representative
FRD Europe B.V.
Proostwetering 29
3543 AB Utrecht, The Netherlands
Tel.: +31-(0)30-2412277 Fax: +31-(0)30-2412305

Book No. : Fx15-201E
Date of Issue : March 2011