

# ***PARTS LIST***

## ***Fx45-2***

HYDRAULIC BREAKER

APPLICABLE SERIAL NUMBER 6001 AND UP



## **SUPPLY PERIOD OF SPARE PARTS**

Thank you for purchasing a Furukawa Rock Drill product.

Please note that the supply of spare parts will be assured for 10 years after the termination of production in accordance with the guidelines for the supply of spare parts as specified by the Japan Construction Equipment Manufacturers Association.

Although the supply of spare parts is terminated in principle at the maturity of the subject supply period, we may be able to supply them upon request even after the expiration of the supply period on condition that the delivery date and price are subject to negotiation.

Even if it is within the supply period, however, the delivery date, price, etc. may be subject to negotiation when it is difficult to keep stocks should the purchased parts, such as electronic parts, etc., be not available because the manufacturer does not produce them any more.

If you have any questions about any particular model subject to the warranty as stated above and the time limit of spare parts supply, please contact your nearest FRD Europe B.V. distributor.

# USING THE PARTS LIST

1. This parts list describes the components of a hydraulic breaker.
2. When ordering a part, refer to the illustrations and lists in this parts list and then inform the FRD Europe B.V. distributor in your area of the following items.
  - (1) Model name
  - (2) Serial No.
  - (3) Part No.
  - (4) Part name
  - (5) Quantity
3. Use "Genuine Furukawa Rock Drill Parts" when replacing all parts.
4. The illustrations in this parts list show the positions and shapes of the parts so that a user can order a part without any problem.

Do not repair a hydraulic breaker by using this parts list.
5. The parts in this list are subject to change for improvement without notice on the part of the manufacturer.

## How to use the parts list

### (1) Illustration

- ① Group Name .....This is the same as the Group Name on the CONTENTS.
- ② Fig. No.....This shows the illustration number and corresponds to Fig. No. of the parts breakdown.
- ③ Item .....This corresponds to Item in the parts breakdown.
- ④ Group Name .....This shows the group name in which the parts breakdown is covered in a separate page in this parts list.
- ⑤ Page.....The left side of “—” (hyphen) shows consecutive numbers in each unit. The right side shows consecutive numbers of drawings/lists in each unit.

### (2) Parts Breakdown

- ① Item .....This is shown by three figures and corresponds to Item in the illustration. Item nos. are not always in sequence.  
When a part has been changed in design and then the part number or quantity has been changed, a sub-number is added to Item in order to show the order of change.
- ② Part No.....(a) Part number is shown.  
(b) Indication of a no-service part  
With parts which cannot be serviced as a single part, only the illustrations and part names are given and the mark \* is shown in the part number column. These parts are serviced as an assembly, a kit or a set.
- ③ Part Name.....This shows the description of a part. When following marks are put before the part name:  
No mark ..... Represents a single part or an assembly component.  
\* ..... Represents a part or an assembled part of the assembly component. It is listed out after the assembly name.  
\*\*..... Represents a part of the assembled part of the assembly component.
- ④ Q' ty .....As a rule, this column indicates the quantity of a part required for one breaker. In case of a part of an assembly component, however, it indicates the quantity of the part required for one assembly component. In this column, the following mark is also used besides the numerals to indicate the quantity of parts.  
( ) Parenthesis..... This part does not include an assembly. . . . Option etc.  
AR ..... As required.
- ⑤ Serial No. ....Serial No. in which this part is used is as shown in the following example:

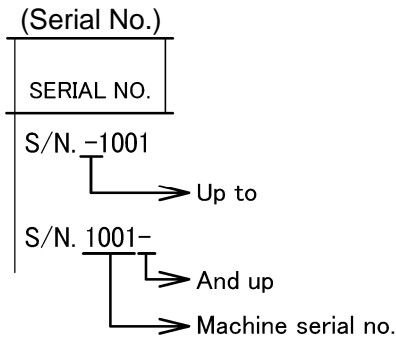

⑥ Remarks ..... The marks and part numbers in the Remarks column are described below.

A ..... Replaceable common part and following part no.

B ..... Represents that this part is not supplied as a single part, however, it is supplied as a set.

Refer to Replaceable Parts List at the end of the parts list.

C ..... Represents that this part is not supplied as a single part.

When an assembly including this part is supplied, the parts after this mark are supplied. When no parts are given after this mark, the components of this part are supplied.

D ..... This part is no longer manufactured due to an incorrect part number or a change and supplying this part is discontinued. When a substitute can be supplied, the part number after this mark is supplied.

⑦ Page ..... The left side of “-” (hyphen) shows consecutive numbers in each unit. The right side shows consecutive numbers of drawings/lists in each unit.

# Name of Components or Component Group

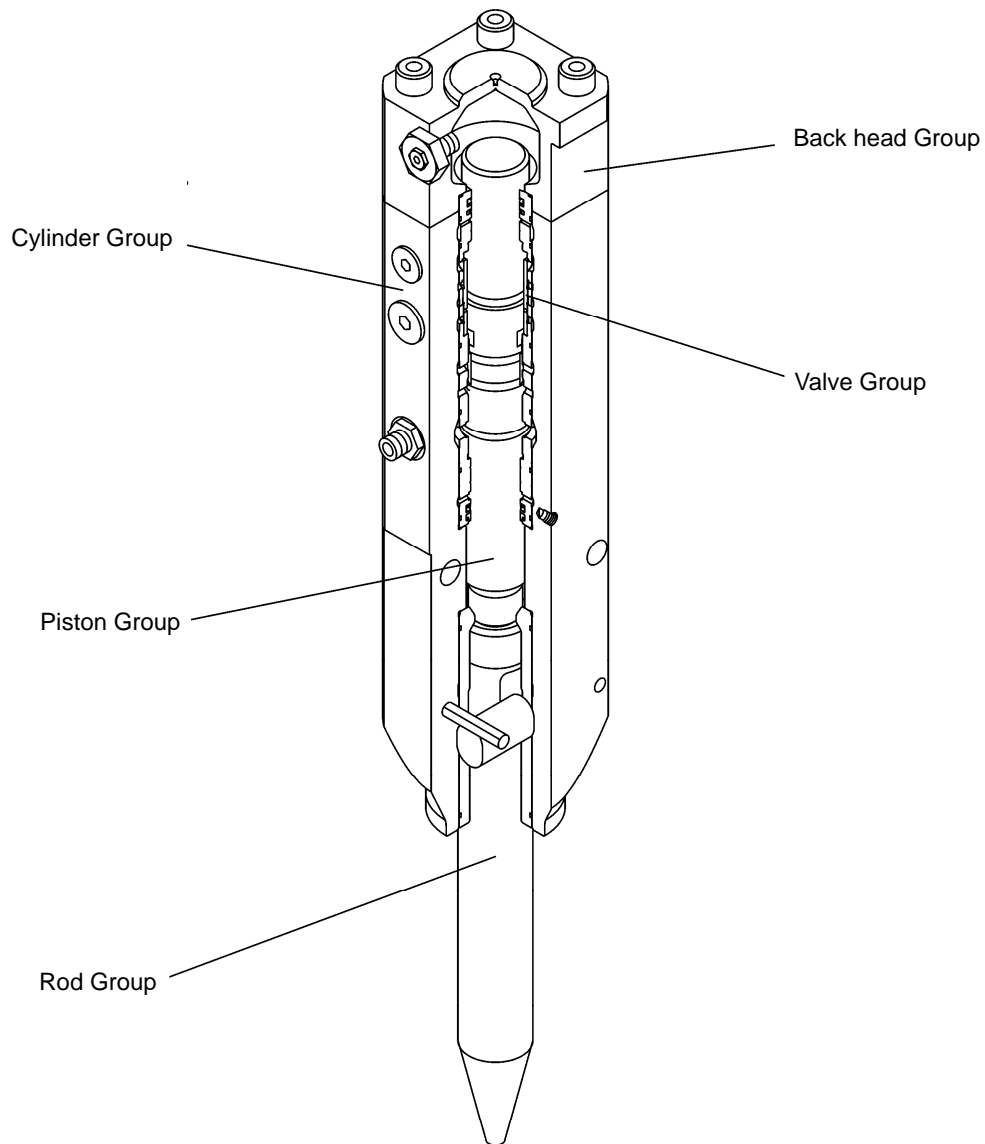

## CONTENTS

FIG.NO.	GROUP NAME	PAGE
902308-000010	BREAKER BODY UNIT	01-01
902308-920010	SEAL KIT	02-01
902308-800010	BRACKET	03-01
902308-822010	FLAT TOP BRACKET	04-01
902308-880010	S-BOX	05-01
902308-880100	XS-BOX	06-01
	TOP BRACKET	07-01
	HYDRAULIC HOSE ASSEMBLY	08-01
	STICKERS	09-01
	STANDARD TOOLS	10-01
	BACK HEAD PRESSURE CHARGING KIT	11-01
	MAINTENANCE KITS	12-01

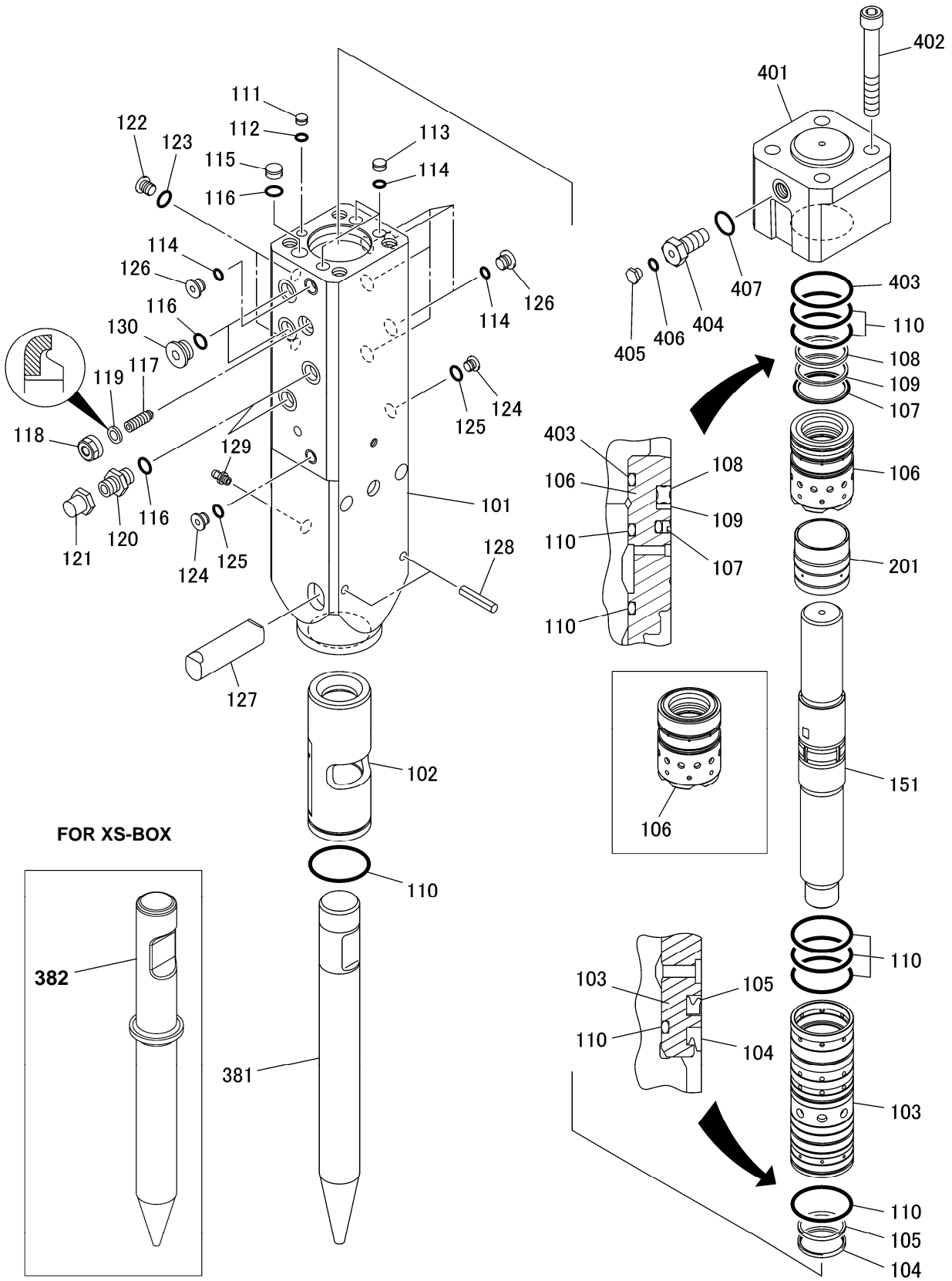



ITEM	PART NO.	PART NAME	Q'TY	REMARKS
101	002308-100060	CYLINDER	1	
102	002308-100070	FRONT LINER	1	
103	002308-100080	CYLINDER LINER	1	
104	HB4R-10106	DUST SEAL	1	R1
105	HB4R-10107	U-PACKING	1	R1
106	002308-100090	SEAL RETAINER	1	
107	002303-100030	STEP SEAL	1	R1
108	002303-100041	QUAD RING	1	R1
109	002303-100050	BACK-UP RING	1	R1
110	161021-00080	O-RING	7	R1
111	HB2R-10120	PLUG	1	R1
112	160011-10010	O-RING	1	R1
113	HB5G-10120	PLUG	3	R1
114	160011-00014	O-RING	9	R1
115	002301-100060	PLUG	1	R1
116	160011-00018	O-RING	5	R1
117	F4-10231	ADJUSTER	1	
118	F4-10233	SEAL NUT	1	
119	HB1G-10532	SEAL WASHER	1	R1
120	084861-04000	MALE CONNECTOR	2	
121	084898-04000	UNION CAP	2	
122	084891-01000	GPF PLUG	2	
123	160011-00008	O-RING	2	R1
124	084891-02000	GPF PLUG	2	
125	160011-00011	O-RING	2	R1
126	084891-03000	GPF PLUG	6	
127	002308-100050	ROD PIN	1	MK1, MK2
128	154037-12065	SPRING PIN	1	MK1, MK2
129	170312-00000	GREASE NIPPLE	1	
130	084891-04000	GPF PLUG	2	
151	002308-110030	PISTON	1	
201	002308-130012	VALVE	1	
381	F4-25111	FLAT ROD	1	ALTERNATIVE
381	F4-25113	MOIL POINT	1	ALTERNATIVE
381	F4-25114	WEDGE ROD	1	ALTERNATIVE
381	F4-25115	CONE ROD	1	ALTERNATIVE
381	F4-25116	BALL POINT ROD	1	ALTERNATIVE

ITEM	PART NO.	PART NAME	Q'TY	REMARKS
382	002308-250050	FLAT ROD, XS	1	ALTERNATIVE, XS-BOX
382	002308-250060	CONE ROD, XS	1	ALTERNATIVE, XS-BOX
382	002308-250070	BALL POINT ROD, XS	1	ALTERNATIVE, XS-BOX
401	002308-300011	BACK HEAD	1	
402	102032-20150	SOCKET BOLT	4	
403	161021-00080	O-RING	1	R1
404	HB15G-30103	CHARGING VALVE	1	
405	HB20G-30109	PLUG	1	
406	160011-00006	O-RING	1	R1
407	160011-00018	O-RING	1	R1
	902308-920010	SEAL KIT	*	R1 SEE PAGE 02-01
	FX45-99000	MAINTENANCE KIT	*	MK1 SEE PAGE 12-01
	FX45-99000W	MAINTENANCE KIT	*	MK2 SEE PAGE 12-01

# SERVICE MEMO

A series of horizontal dashed lines providing space for writing the service memo content.

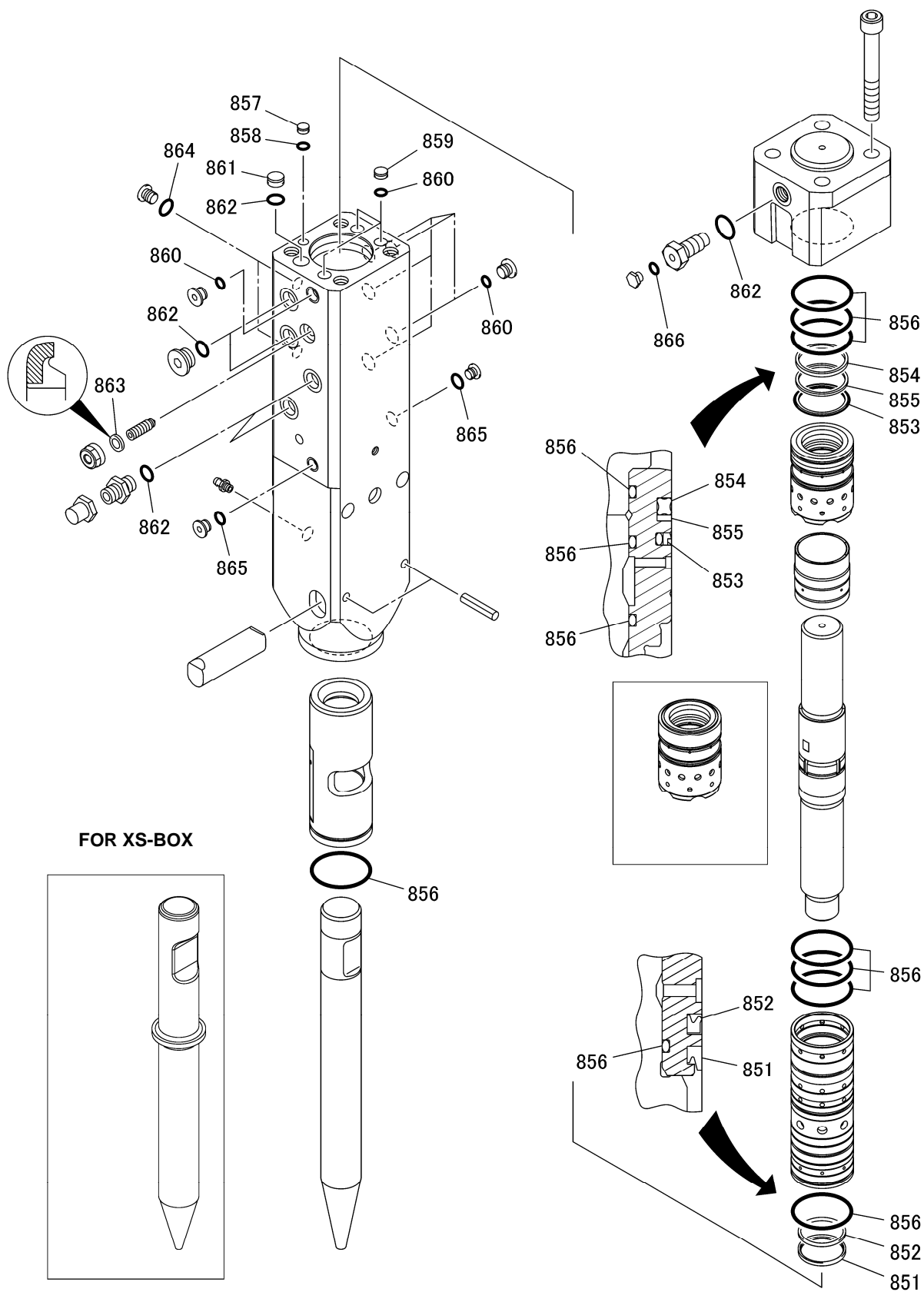

ITEM	PART NO.	PART NAME	Q'TY	REMARKS
	902308-920010	SEAL KIT		
851	HB4R-10106	*DUST SEAL	1	
852	HB4R-10107	*U-PACKING	1	
853	002303-100030	*STEP SEAL	1	
854	002303-100041	*QUAD RING	1	
855	002303-100050	*BACK-UP RING	1	
856	161021-00080	*O-RING	8	
857	HB2R-10120	*PLUG	1	
858	160011-10010	*O-RING	1	
859	HB5G-10120	*PLUG	3	
860	160011-00014	*O-RING	9	
861	002301-100060	*PLUG	1	
862	160011-00018	*O-RING	6	
863	HB1G-10532	*SEAL WASHER	1	
864	160011-00008	*O-RING	2	
865	160011-00011	*O-RING	2	
866	160011-00006	*O-RING	1	

Dimension	A	B	C	D
Part No.				
902308-800010	φ 60 mm	154 mm	214 mm	218 mm

D: Distance between pins

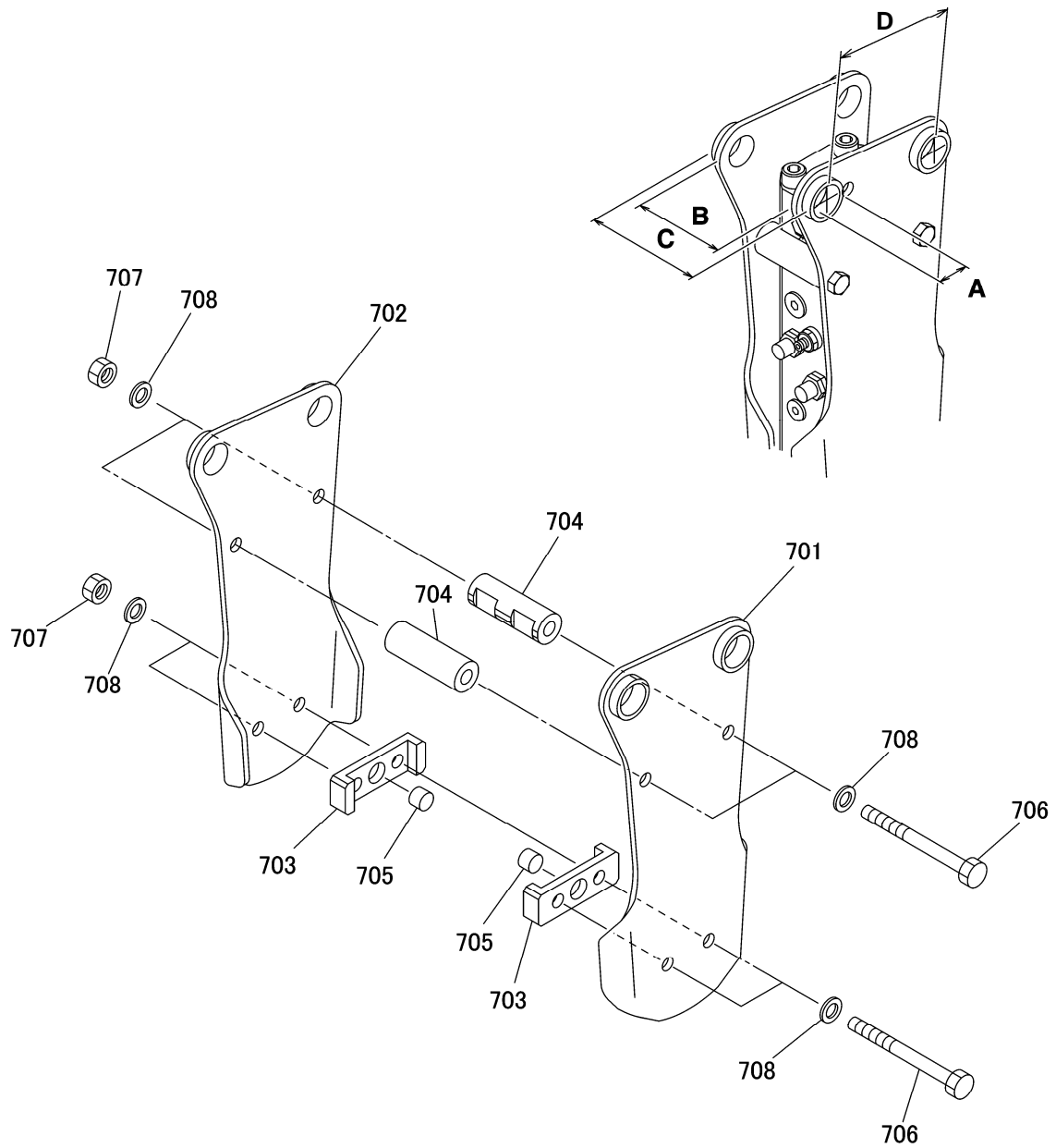

ITEM	PART NO.	PART NAME	Q'TY	REMARKS
	902308-800010	BRACKET ASSEMBLY		
701	002308-800010	*BRACKET (R)	1	
702	002308-800020	*BRACKET (L)	1	
703	002308-810061	*SET PLATE	2	
704	002308-810071	*DISTANCE PIPE	2	
705	002308-810081	*SET PIN	2	
706	101032-22210	*BOLT	4	
707	120132-22000	*NUT	4	
708	HB4R-81114E	*NORD-LOCK WASHER	8	

Top bracket mounting dimensions:

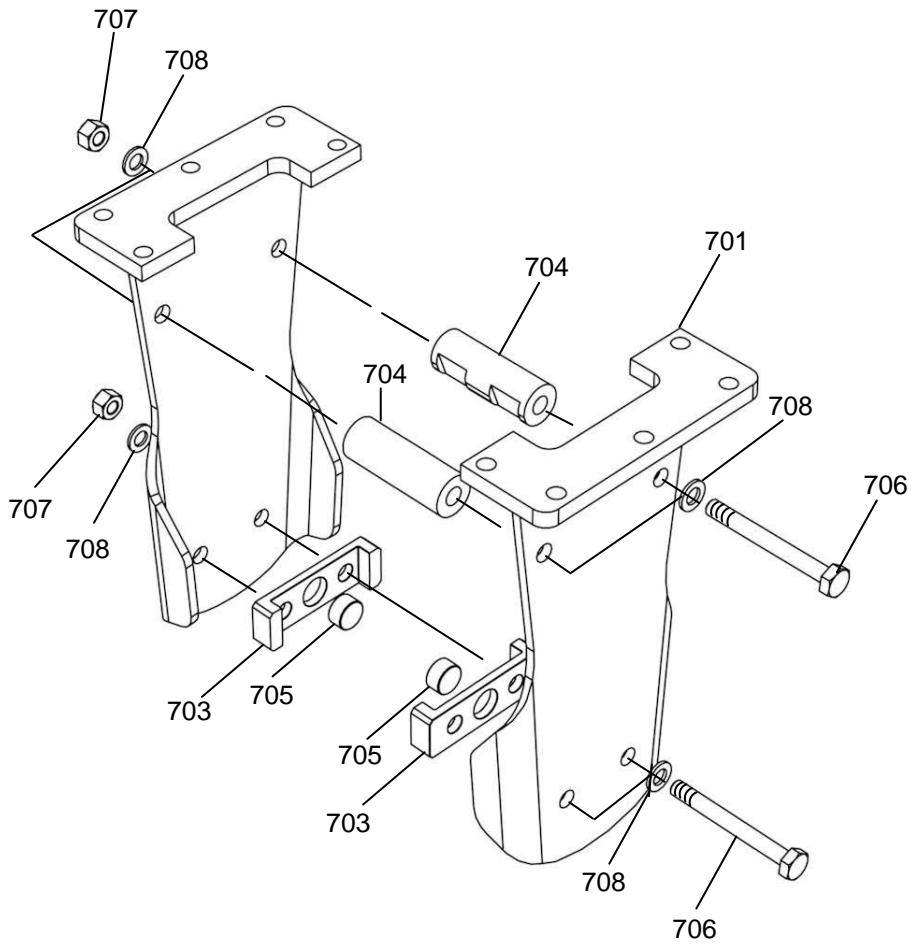
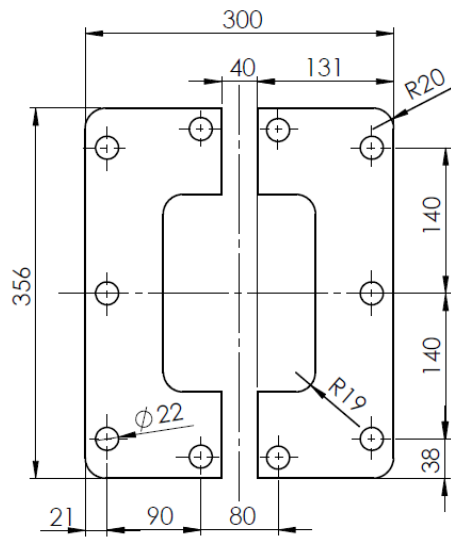



ITEM	PART NO.	PART NAME	Q'TY	REMARKS
	902308-822010	BRACKET ASSEMBLY		
701	002308-822010	*BRACKET (R)	1	
702	002308-822020	*BRACKET (L)	1	
703	002308-810061	*SET PLATE	2	
704	002308-810071	*DISTANCE PIPE	2	
705	002308-810081	*SET PIN	2	
706	101032-22210	*BOLT	4	
707	120132-22000	*NUT	4	
708	HB4R-81114E	*NORD-LOCK WASHER	8	

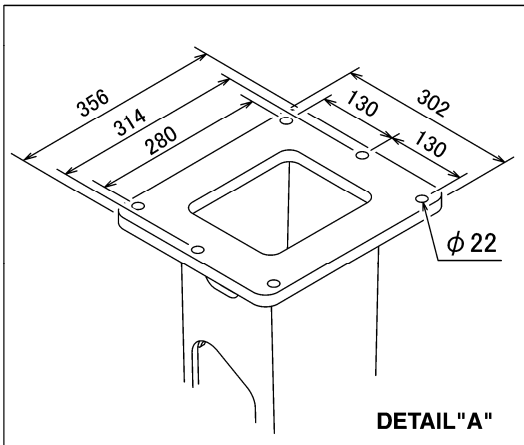

TRANSPORT (WITHOUT TOP BRACKET)

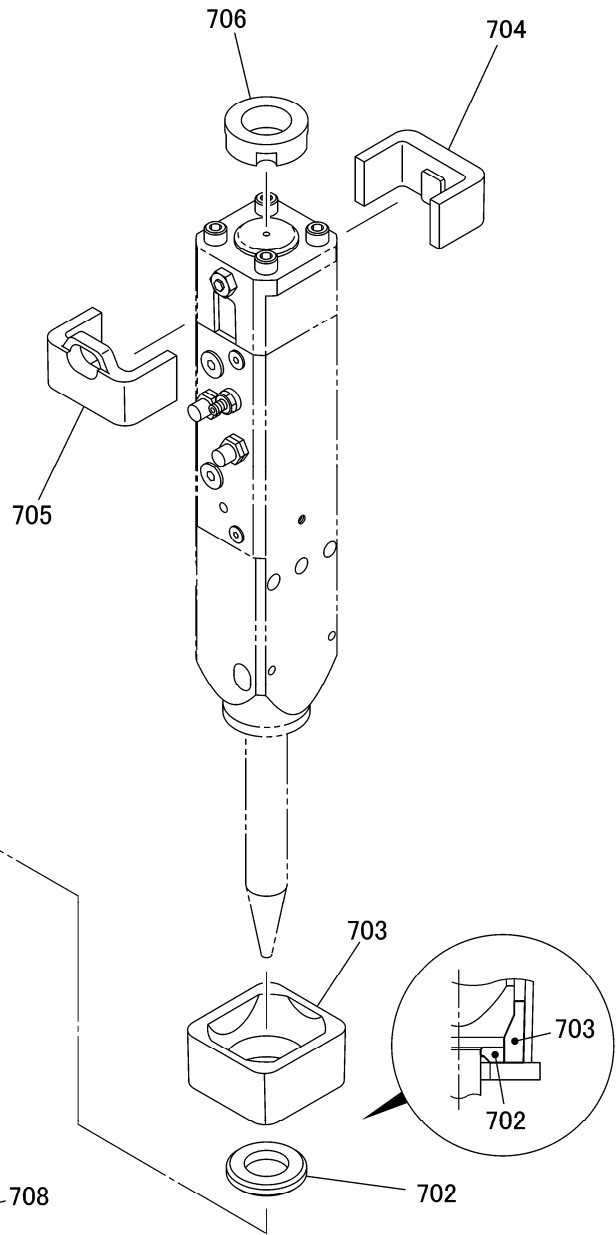
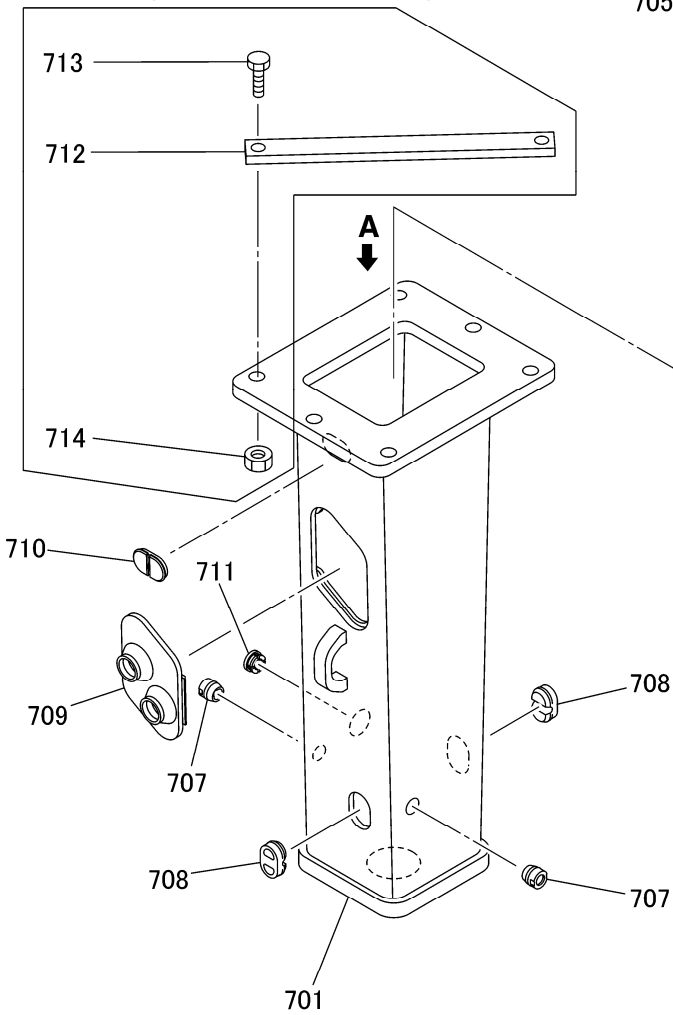

ITEM	PART NO.	PART NAME	Q'TY	REMARKS
	902308-880010	S-BOX ASSEMBLY		
701	002308-880010	*S-BOX	1	
702	002308-880020	*BOTTOM DAMPER	1	
703	002308-880030	*FRONT DAMPER	1	
704	002308-880040	*BACK DAMPER(A)	1	
705	002308-880050	*BACK DAMPER(B)	1	
706	002308-880060	*TOP DAMPER	1	
707	002308-880070	*DUST PLUG	2	
708	002308-880080	*PIN PLUG	2	
709	002308-880090	*SOUNDPROOF COVER	1	
710	002308-880100	*DUST PLUG	1	D 002308-880101
710	002308-880101	*DUST PLUG	1	D 002308-880102
710	002308-880102	*DUST PLUG	1	S/N 2328 -
711	002200-830160	*GREASE CAP	1	D 002200-830161
711	002200-830161	*GREASE CAP	1	
712	F4-88231	*FLAT BAR	1	TRANSPORT (WITHOUT TOP BRACKET)
713	101012-20050	*BOLT	2	TRANSPORT (WITHOUT TOP BRACKET)
714	120112-20000	*NUT	2	TRANSPORT (WITHOUT TOP BRACKET)

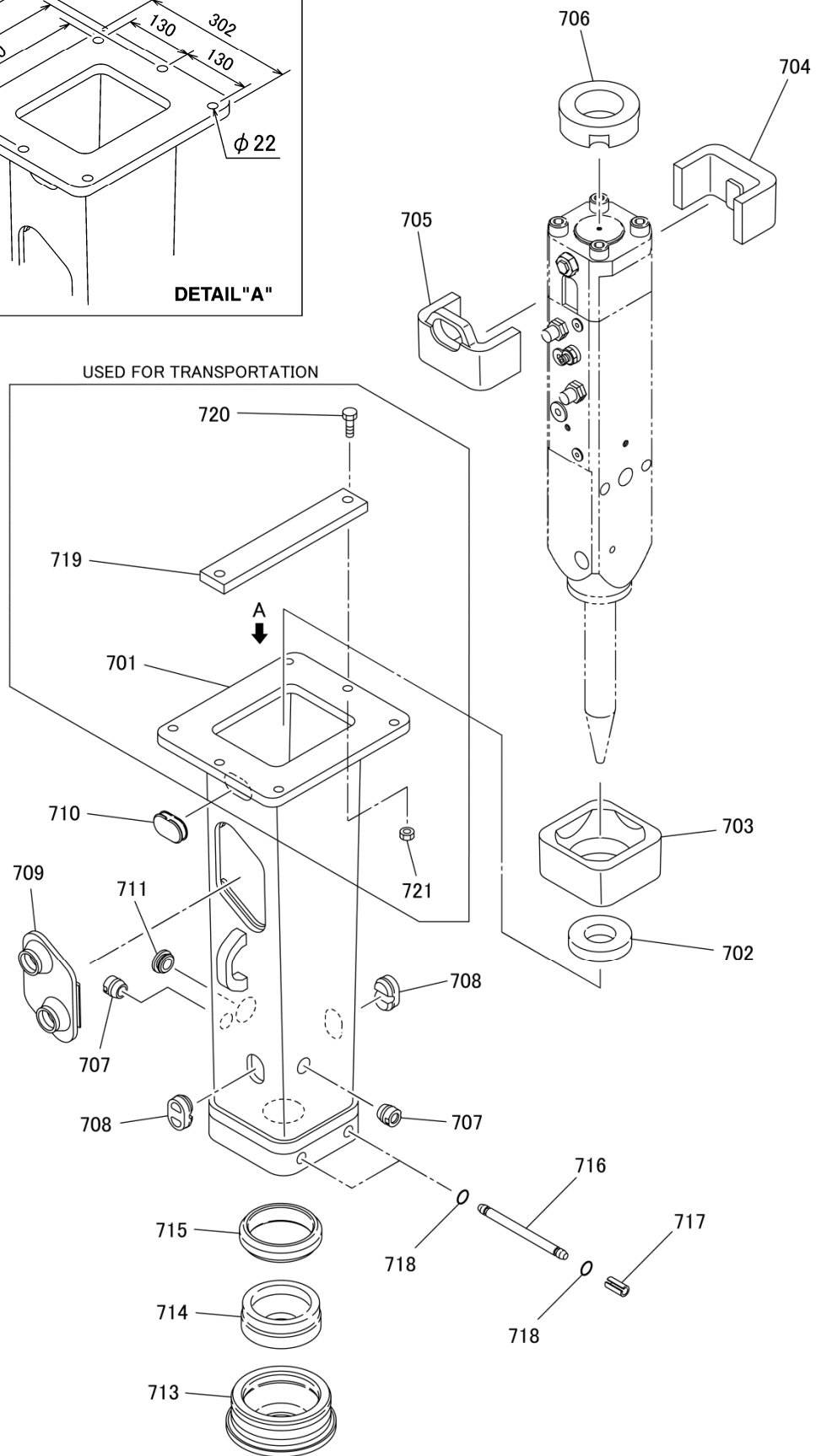
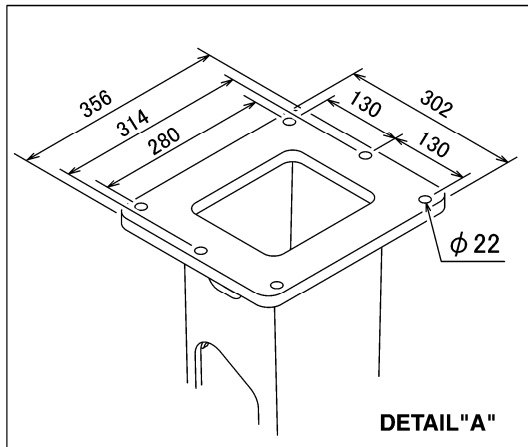

ITEM	PART NO.	PART NAME	Q'TY	REMARKS
	902308-880110	XS-BOX ASSEMBLY		
701	002308-880110	*XS-BOX	1	
702	002308-830080-A	*RING, XS	1	
703	002308-880030	*FRONT DAMPER	1	
704	002308-880040	*BACK DAMPER(A)	1	
705	002308-880050	*BACK DAMPER(B)	1	
706	002308-880060	*TOP DAMPER	1	
707	002308-880070	*DUST PLUG	2	
708	002308-880080	*PIN PLUG	2	
709	002308-880090	*SOUNDPROOF COVER	1	
710	002308-880100	*DUST PLUG	1	D 002308-880101
710	002308-880101	*DUST PLUG	1	D 002308-880102
710	002308-880102	*DUST PLUG	1	S/N 2328 -
711	002200-830160	*GREASE CAP	1	D 002200-830161
711	002200-830161	*GREASE CAP	1	
713	002308-830070	*CAP	1	
714	002308-830090	*PROTECT SEAL	1	
715	002308-830100	*SUPPORT RING	1	
716	002308-830111	*STOP PIN	2	
717	154037-14030	*SPRING PIN	2	
718	160011-10010	*O-RING	4	
719	F4-88231	*FLAT BAR	1	TRANSPORT (WITHOUT TOP BRACKET)
720	101012-20050	*BOLT	2	TRANSPORT (WITHOUT TOP BRACKET)
721	120112-20000	*NUT	2	TRANSPORT (WITHOUT TOP BRACKET)

# TOP BRACKET

---

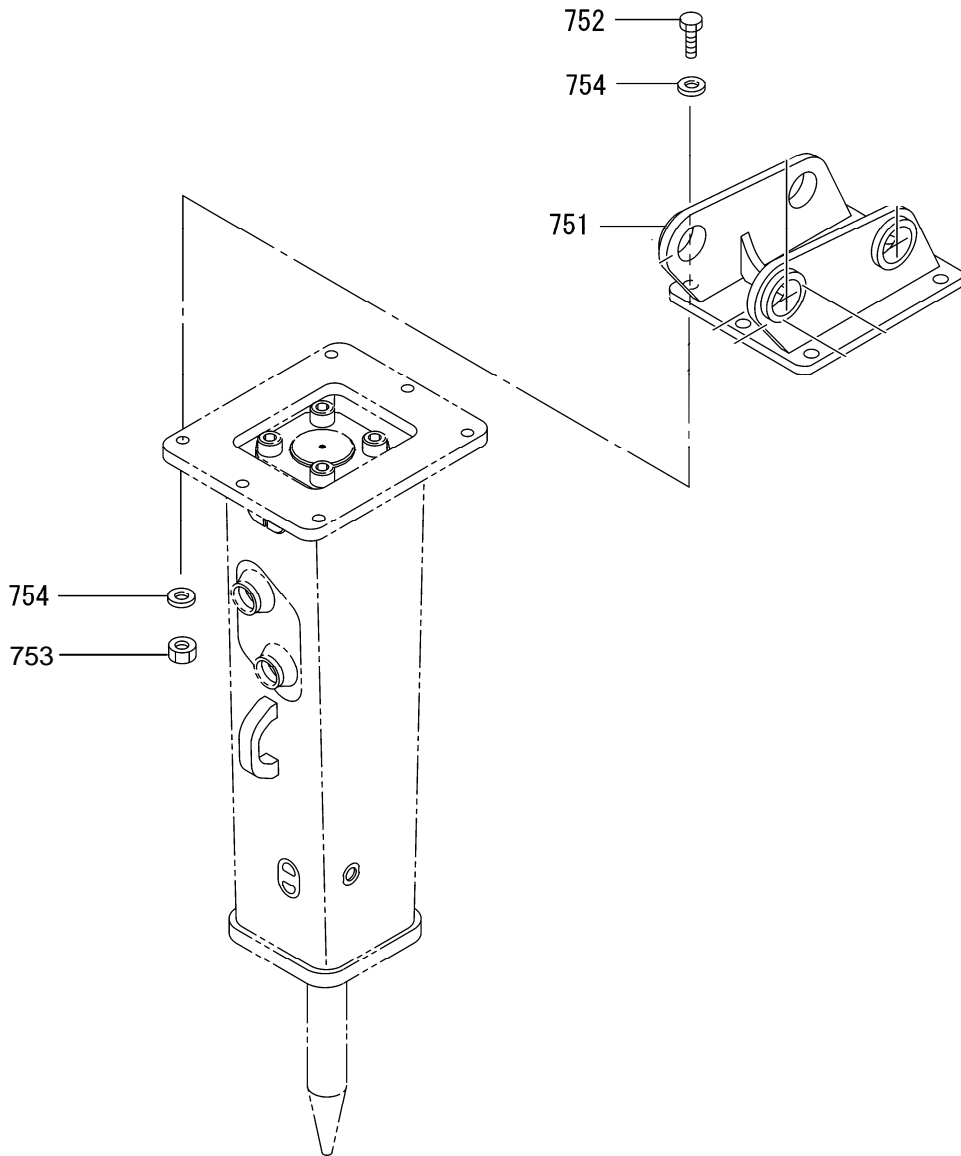

ITEM	PART NO.	PART NAME	Q'TY	REMARKS
751		TOP BRACKET	1	FLAT TOP BRACKET
752	101032-20080	BOLT	10	
753	120132-20000	NUT	10	
754	140112-20000	WASHER	10	
751		TOP BRACKET	1	S-BOX AND XS-BOX
752	101032-20080	BOLT	6	
753	120132-20000	NUT	6	
754	140112-20000	WASHER	6	

# HYDRAULIC HOSE ASSEMBLY

---

## BRACKET AND FLAT TOP BRACKET

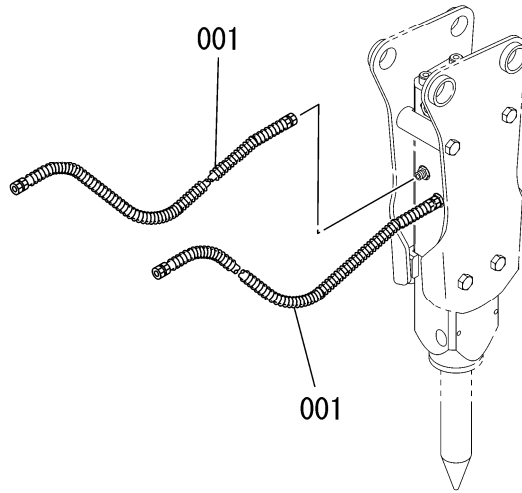

## S-BOX AND XS-BOX

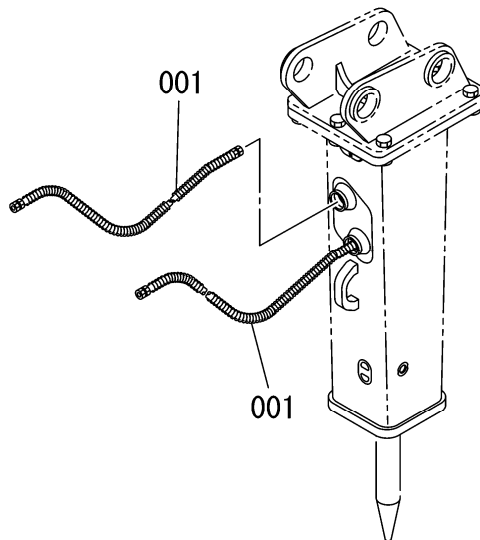



ITEM	PART NO.	PART NAME	Q'TY	REMARKS
001	1003346	HYDRAULIC HOSE ASSEMBLY HYDRAULIC HOSE	2	FOR BRACKET, FLAT TOP BRACKET, S-BOX AND XS-BOX

# STICKERS

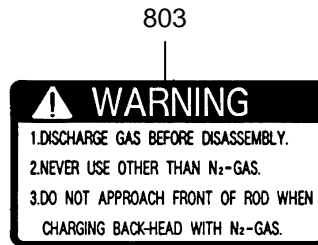
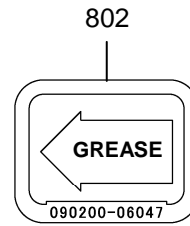
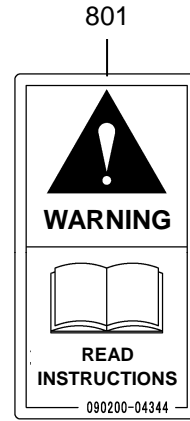
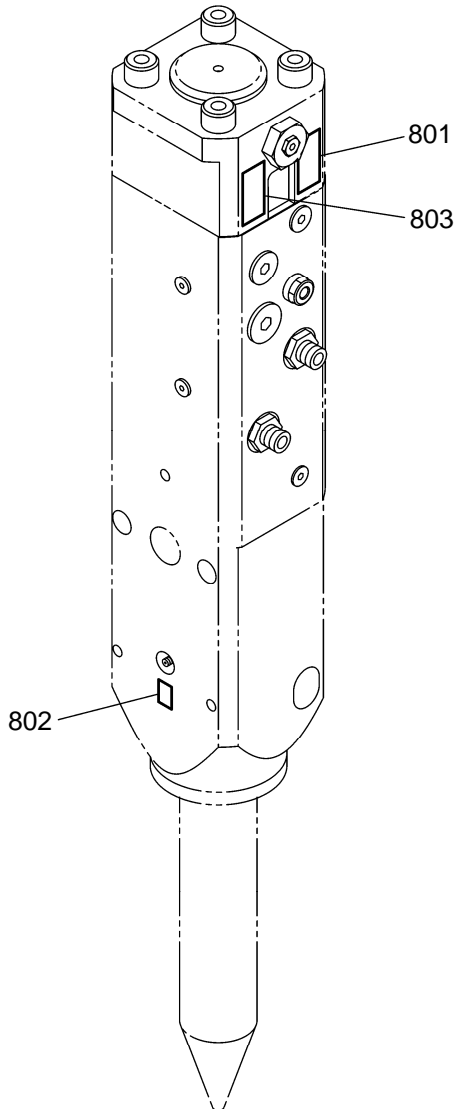

ITEM	PART NO.	PART NAME	Q'TY	REMARKS
801	090200-04344	WARNING STICKER	1	ENGLISH
802	090200-06047	CAUTION STICKER	1	ENGLISH
803	090200-04209	WARNING STICKER	1	ENGLISH FOR STICKERS IN OTHER LANGUAGES PLEASE ASK YOUR NEAREST FRD DISTRIBUTOR

801



802 ~ 805, 814

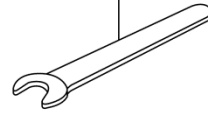

806 807 808 809 810

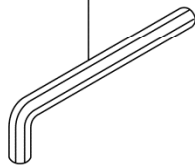

811



812

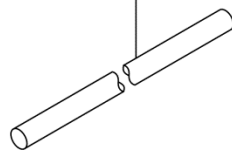

813



815



816a



816b



ITEM	PART NO.	PART NAME	Q'TY	REMARKS
	903208-900011	TOOL KIT	1	
801	090012-91015	*TOOL CASE	1	
802	090012-11010	*14mm SPANNER	1	
803	090012-11014	*22mm SPANNER	1	
804	090012-11018	*27mm SPANNER	2	
805	090012-11021	*32mm SPANNER	2	
806	090012-17006	*5mm HEXAGON BAR WRENCH	1	
807	090012-17007	*6mm HEXAGON BAR WRENCH	1	
808	090012-17008	*8mm HEXAGON BAR WRENCH	1	
809	090012-17009	*10mm HEXAGON BAR WRENCH	1	
810	090012-17012	*17mm HEXAGON BAR WRENCH	1	
811	117012-12000	*EYE BOLT	2	
812	002308-900010	*PRESS PIN	1	
813	HB1G-10532	*SEAL WASHER	1	
814	090012-11009	*13mm SPANNER	2	
815	244-10215-5	GREASE GUN (MANUAL)	1	
816a	FGC-06713	GREASE CARTRIDGE	1	SENCIO BLUE
816b	FGC-06625	GREASE CARTRIDGE	1	SENCIO WHITE

# BACK HEAD PRESSURE CHARGING KIT

---

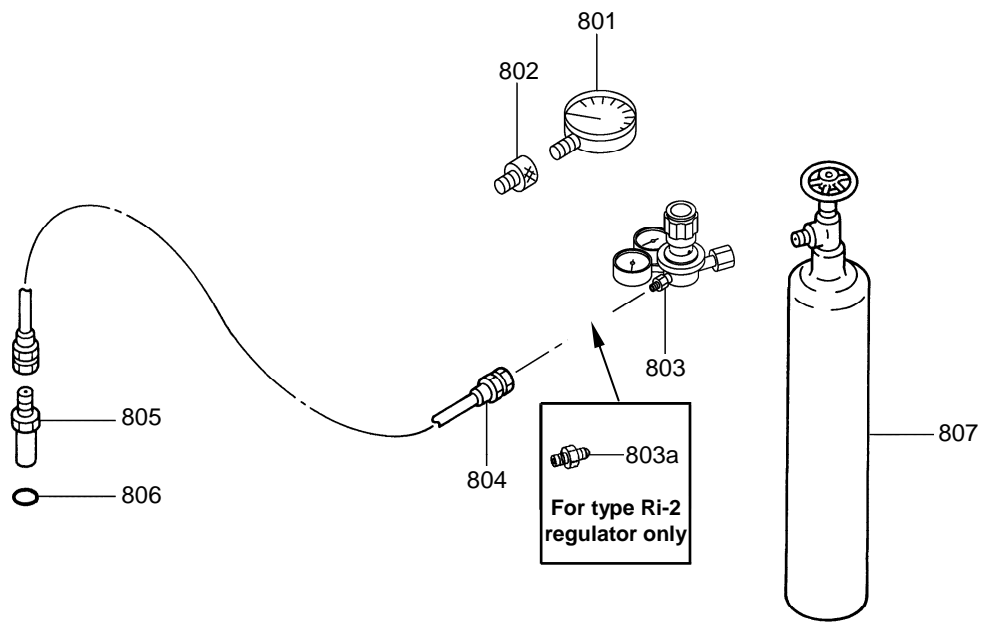

ITEM	PART NO.	PART NAME	Q'TY	REMARKS
801	HB20G-920131 H-11016	BACK HEAD CHARGING KIT *PRESSURE GAUGE	1	FOR: AUSTRIA, BULGARIA, CZECH REP., DENMARK,
802	HB20G-921072	*ADAPTER	1	FINLAND, GERMANY, ICELAND,
803	046072	*REGULATOR (Ru-3)	1	NETHERLANDS, NORWAY,
804	1001766	*CHARGING HOSE	1	POLAND, RUSSIA (MOSCOW),
805	HB20G-921071	*CHARGING ADAPTER	1	SERBIA, SLOVAKIA, SWEDEN,
806	161011-00006	*O-RING	1	SWITZERLAND.
807	-	NITROGEN GAS CYLINDER	1	
801	HB20G-920132 H-11016	BACK HEAD CHARGING KIT *PRESSURE GAUGE	1	FOR: FRANCE, PORTUGAL, ROMANIA, SPAIN.
802	HB20G-921072	*ADAPTER	1	
803	046073	*REGULATOR (B-4)	1	
804	1001766	*CHARGING HOSE	1	
805	HB20G-921071	*CHARGING ADAPTER	1	
806	161011-00006	*O-RING	1	
807	-	NITROGEN GAS CYLINDER	1	
801	HB20G-920133 H-11016	BACK HEAD CHARGING KIT *PRESSURE GAUGE	1	FOR: GREAT BRITAIN, IRELAND MALTA, SOUTH AFRICA.
802	HB20G-921072	*ADAPTER	1	
803	046070	*REGULATOR (Ri-2)	1	
803a	2243-04-06	*CONNECTOR	1	
804	1001766	*CHARGING HOSE	1	
805	HB20G-921071	*CHARGING ADAPTER	1	
806	161011-00006	*O-RING	1	
807	-	NITROGEN GAS CYLINDER	1	
801	HB20G-920134 H-11016	BACK HEAD CHARGING KIT *PRESSURE GAUGE	1	FOR: BELGIUM, CYPRUS, ESTONIA, GREECE, HUNGARY,
802	HB20G-921072	*ADAPTER	1	ISRAEL, ITALY, LATVIA,
803	046071	*REGULATOR (Ru-1)	1	LITHUANIA, RUSSIA (GENERAL)
804	1001766	*CHARGING HOSE	1	UKRAINE.
805	HB20G-921071	*CHARGING ADAPTER	1	
806	161011-00006	*O-RING	1	
807	-	NITROGEN GAS CYLINDER	1	

# MAINTENANCE KITS

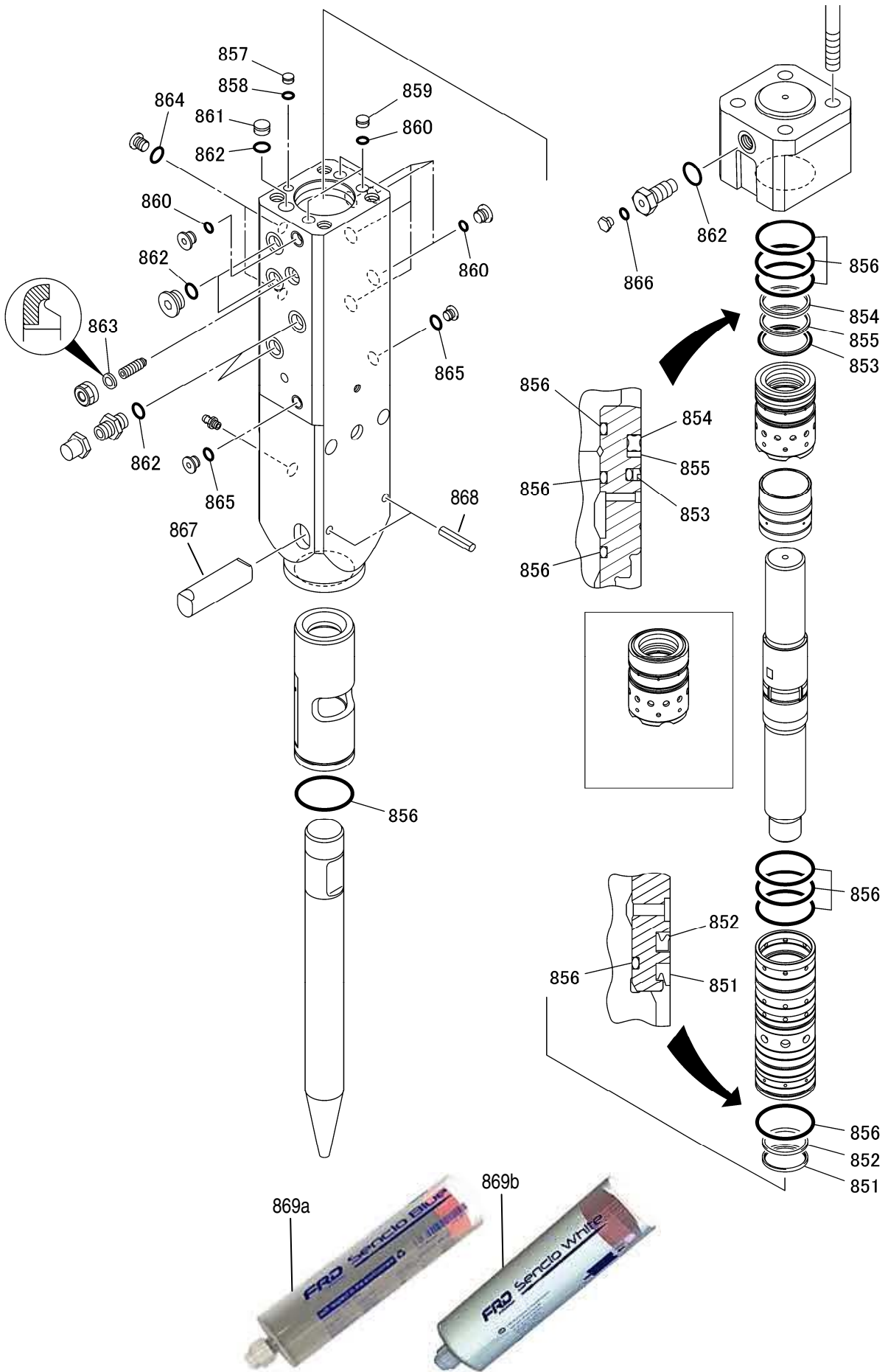



ITEM	PART NO.	PART NAME	Q'TY	REMARKS
	FX45-99000	MAINTENANCE KIT		
*	902308-920010	*SEAL KIT (ITEMS 851 ~ 866)	1	
867	002308-100050	*ROD PIN	1	
868	154037-12065	*SPRING PIN	1	
869a	FGC-06713	*GREASE CARTRIDGE	1	SENCIO BLUE
	FX45-99000W	MAINTENANCE KIT		
*	902308-920010	*SEAL KIT (ITEMS 851 ~ 866)	1	
867	002308-100050	*ROD PIN	1	
868	154037-12065	*SPRING PIN	1	
869b	FGC-06625	*GREASE CARTRIDGE	1	SENCIO WHITE

**FRD**  
FURUKAWA **FURUKAWA ROCK DRILL CO.,LTD.**

5-3, 1-chome, Nihonbashi-muromachi, Chuo-ku,  
Tokyo, 103-0027, Japan.  
Phone:81-3-3231-6982 Fax:81-3-3231-6994

**Book No. : 902308-D101020-1E**  
**Date of Issue : October 2016**

