

X1500 Round Earth Drill - Parts List

From Serial Number 20012341

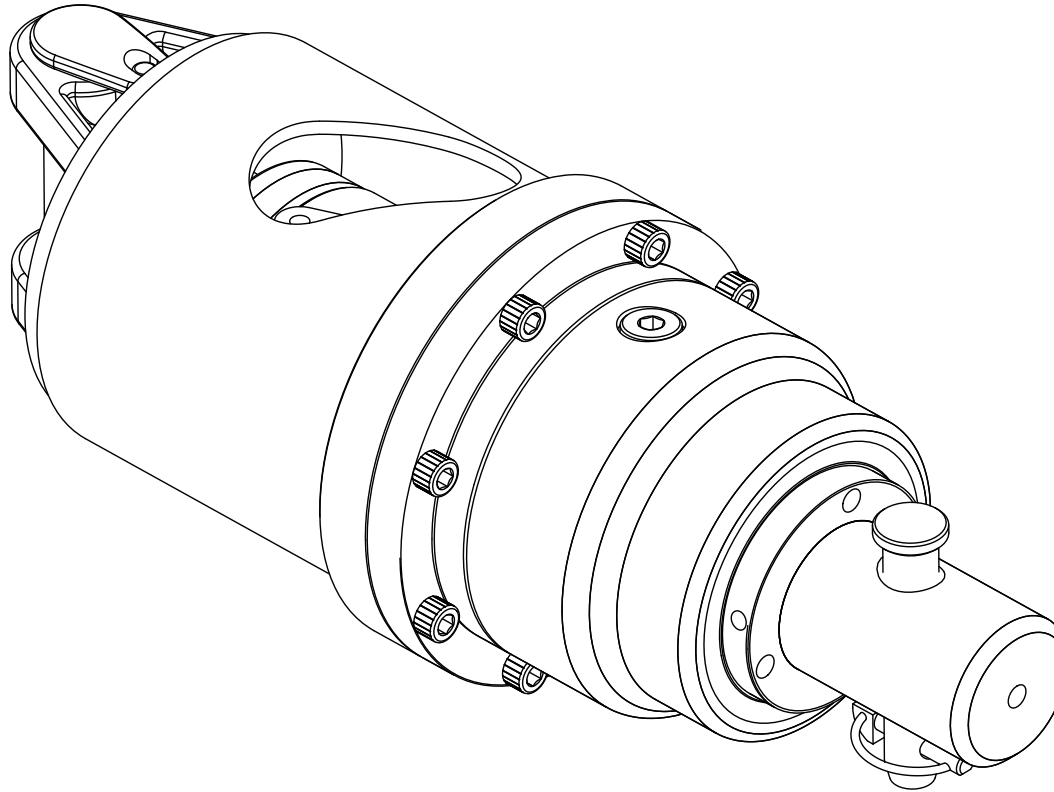

X1500 Round Earth Drill - Parts List



From Serial Number 20012341

FOREWORD

This document is the property of Auger Torque and the information contained herein is confidential to the company. The contents of the document must not be reproduced or disclosed wholly or in part, or used for purposes other than that for which it has been supplied, without the prior written permission of Auger Torque.

This manual has been written in the standard United Kingdom English Language. Auger Torque accepts no responsibility or liability for customer or any other third party translations of this manual into other languages, or for any incidents arising from such translation.

Auger Torque operates a policy of continuous product improvement, and actively encourages feedback on user manuals. If you wish to comment on the contents of this manual please send your comments using the feedback form provided. Please copy and complete the hard copy form on the back page of this manual.

SAFETY

Auger Torque Earth Drill Units have been designed for use with specific Auger Torque mounting frames, Augers, Auger extensions and Auger wear parts. Provided these are used and maintained correctly, they will provide a safe and reliable method of boring holes in the earth.

Use of this product following unauthorised modifications or repairs, use by untrained personnel, by implementing unsafe systems of work, by making modifications to product supplied or through operation in any manner not intended by Auger Torque could result in death, serious injury, damage to property or the product itself, and will invalidate any product validation or warranty. Auger Torque accepts no responsibility whatsoever for such modifications, repair or use.

WARRANTY

Auger Torque is not responsible for nor will accept any charges for work carried out by any unauthorised repairers. Charges, including those for spare parts, will not be accepted unless they have been authorised in writing by Auger Torque.

Any goods returned to Auger Torque by the customer, under warranty or for repair, must be freight paid unless authorised in writing by Auger Torque.

For full terms and condition see:-

www.augertorque.com/about-us/warranties.html

CONTACT DETAILS

Please contact your local dealer / distributor via our website

www.augertorque.com/dealer-locator.html

Auger Torque Europe Ltd.
Tel: +44 (0) 1451 861 652

Auger Torque Australia Pty Ltd.
Tel: +61 (0) 7 3274 2077

Attachment Torque MFG(China) Co.,Ltd
Tel: +86 (0) 574 88488181

Auger Torque USA LLC.
Tel: +1 260 200 1500

X1500 Round Earth Drill - Parts List

From Serial Number 20012341

THE MACHINERY DIRECTIVE

The Machinery Directive 2006/42/EC (formerly 98/37/EEC) provides the harmonisation of the essential health and safety requirements for machinery, through a combination of mandatory health and safety requirements and voluntary harmonised standards. Such directives apply only to products that are intended to be placed on or put into service in the market for the first time.

The manufacturer or the authorised representative must draw up a 'Declaration of Conformity'.

Declaration of Conformity

Where Earth Drill Units are supplied in conjunction with Auger Torque manufactured mounting frames and Augers to form an Earth Drill Assembly, Auger Torque have control over the suitability of the parts supplied. To show this and meet with the lawful requirements of the Machinery Directive a Declaration of Conformity is issued and a CE mark is applied to the assembly.

SYMBOLS AND ABBREVIATIONS

The symbols that follow are used within this publication



Safety Glasses to be worn



Gloves/hand protection to be used



Safety shoes to be worn



Torque Tightening required

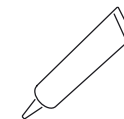

Thread treatment required



Refer to Interchangeability Chart

X1500 Round Earth Drill - Parts List



From Serial Number 20012341

ILLUSTRATED PARTS LIST.

- A** The Illustrated Parts List helps the supply procedure and the identification of replacement component parts.
- B** The Detailed Parts List is divided into seven columns:
- The first column gives the item number of each detailed part contained in the illustration. An item number prefixed by a (-), shows that the item is not illustrated.
 - The second column gives the part number by which the item is identified.
 - The third column, gives the description of the component. The description will be preceded by one or more dots (●).
 - The fourth column gives the quantity of each item in the complete assembly.
 - The fifth column shows the torque tightening required for the item.
 - The sixth column shows the thread treatment required for the item.
 - The seventh column makes reference to any additional information required for the part or assembly.
- C** Only those items with full dots (●) can be ordered as spares. Items with empty dots (eg ●o) are shown only for clarity of assembly and cannot be ordered as spares.

- D** When ordering spare parts please quote the serial number of the Earth Drill, which can be identified from the serial number plate on the top of the unit.

NOTE: Auger Torque will not accept any liability for incorrect parts that may be supplied because an incorrect serial number has been quoted.

The abbreviations that follow are used within this publication

AR	As Required
BSP	British Standard Pipe Thread
cc	Cubic Centimeters
Kg	Kilogrammes
L	Litres
LPM	Litres Per Minute
Mm	Millimeters
Nm	Newton Meters
UNC	Unified Coarse Thread
GPM	Gallons Per Minute
G	Gallons
lbs	Pounds
ft-lbs	Foot Pounds

X1500 Round Earth Drill - Parts List

From Serial Number 20012341

Ref. 15R-0001-1

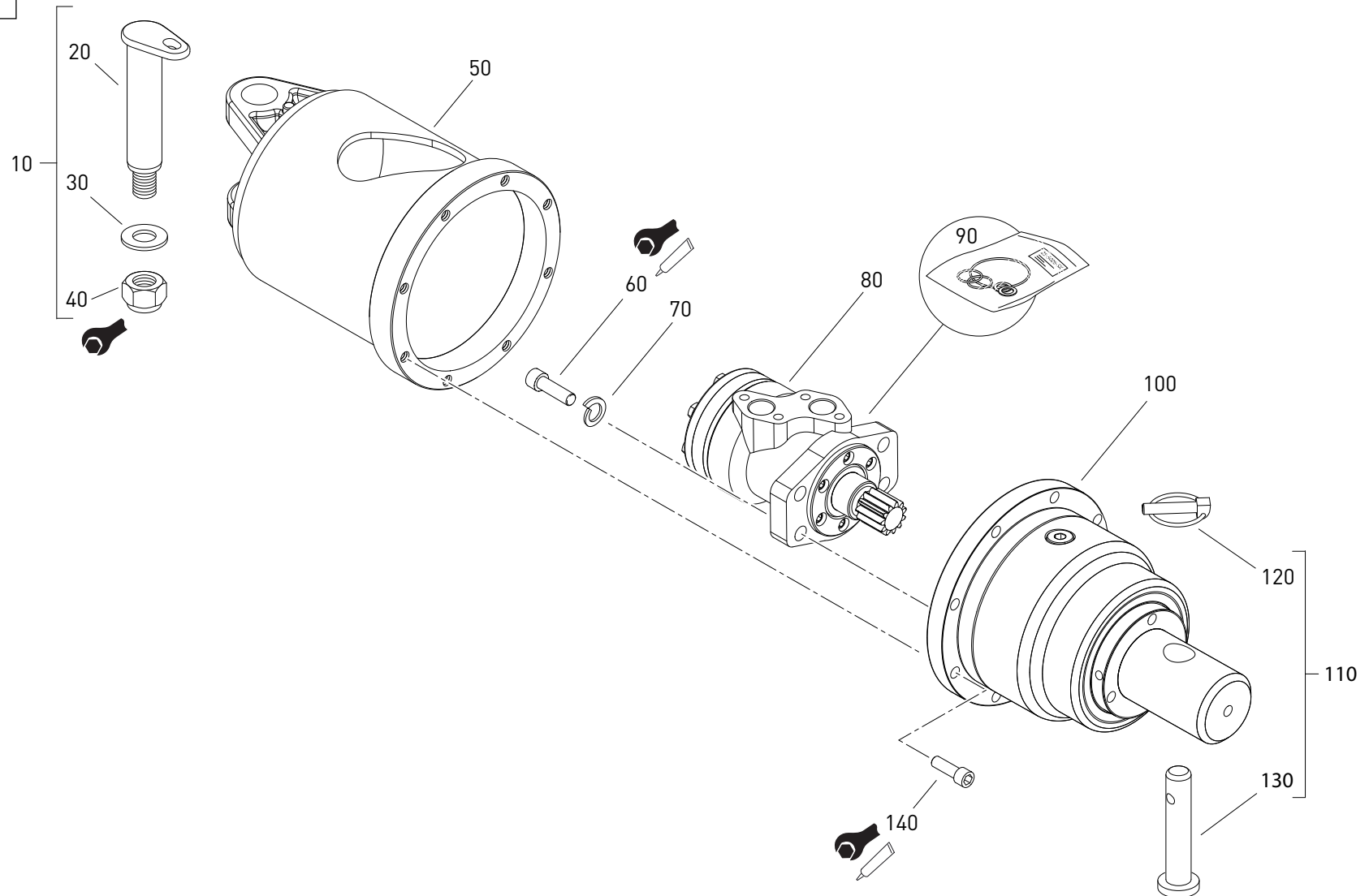

X1500 Round Earth Drill - Parts List



From Serial Number 20012341

ITEM	PART NO.	DESCRIPTION	QTY	TORQUE LOAD	THREAD TREATMENT	NOTES
10	23-2904-KIT	<ul style="list-style-type: none"> ● PIN - HOOD Ø30mm C/W WASHER & NUT 	1			
20	23-2904	<ul style="list-style-type: none"> ● ○ PIN 	1			
30	99-9157	<ul style="list-style-type: none"> ● ○ FIXING - M20 PLAN WASHER 	1			
40	99-9187	<ul style="list-style-type: none"> ● ○ NUT- PLAIN 	1	Refer to Operators Manual		
50	23-2909	<ul style="list-style-type: none"> ● HOOD ASSAY - SERIES 2 - SMRS 80cc MOTOR 	1			
60	99-9135-035	<ul style="list-style-type: none"> ● FIXING - M12 x 35 SOCKET CAP SCREW (12.9 Grade) 	4	121 - 135 Nm	LOCTITE 243	
70	99-9165	<ul style="list-style-type: none"> ● FIXING - M12 SPRING WASHER 	4			
80	25-1313-G	<ul style="list-style-type: none"> ● MOTOR - ATE - 80cc - SMRS - 11T 	1			
90	25-2317	<ul style="list-style-type: none"> ● SEAL KIT - MOTOR 	1			
100	21-2971-R	<ul style="list-style-type: none"> ● DRIVE SUB-ASSEMBLY - SERIES 2 - 5.77:1 - 65mm ROUND 	1			
110	30-0004-KIT	<ul style="list-style-type: none"> ● PIN - AUGER C/W LINCH PIN 	1			
120	99-99020	<ul style="list-style-type: none"> ● ○ LINCH PIN - n9.5 (To fit over UPTO Ø36mm SHAFTS) 	1			
130	30-0004	<ul style="list-style-type: none"> ● ○ PIN 	1			
140	99-9134-035-Y	<ul style="list-style-type: none"> ● FIXING - M10 x 35 SOCKET CAP SCREW (12.9 Grade) YELL.PASS. 	8	69 - 77 Nm	LOCTITE 243	
						Ref. 15R-0001-1

X1500 Round Earth Drill - Parts List

From Serial Number 20012341

Ref. 15R-0002-1

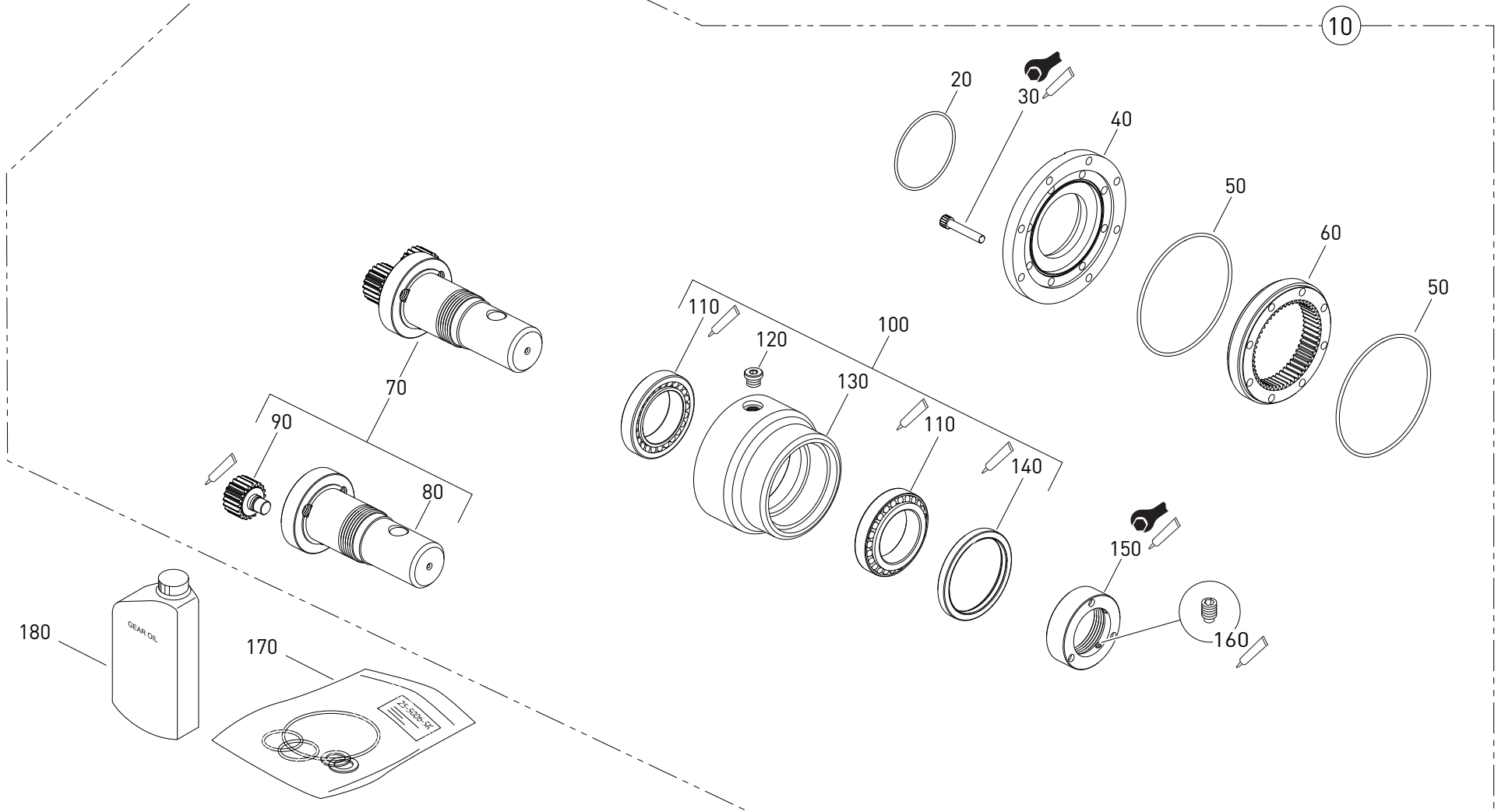

X1500 Round Earth Drill - Parts List



From Serial Number 20012341

ITEM	PART NO.	DESCRIPTION	QTY	TORQUE LOAD	THREAD TREATMENT	NOTES				
10	21-2971-R	<ul style="list-style-type: none"> ● DRIVE SUB-ASSEMBLY - 5.77:1 - 65mm ROUND 	1	69 - 77 Nm	LOCTITE 243	See Seal Kit				
20	99-1540-V	<ul style="list-style-type: none"> ●○ O'RING - 86 ID x 2.5 DIAMETER (Motor seal) 	1							
30	99-9134-060	<ul style="list-style-type: none"> ● FIXING - M10 x 60 SOCKET CAP SCREW (12.9 Grade) 	8							
40	21-2036	<ul style="list-style-type: none"> ● BTM INPUT - SUN FIXED TO MOTOR 	1							
50	99-1531-V	<ul style="list-style-type: none"> ●○ O'RING - 125 x 2.5 (SERIES 2 RING) 	2				350 Nm	See Seal Kit		
60	21-2004	<ul style="list-style-type: none"> ● RING GEAR - 52T - 2.25 MOD. 	1							
70	21-2909-R	<ul style="list-style-type: none"> ● SHAFT ASSY - 65mm ROUND - 5.77 ratio 	1							
80	21-2028-T	<ul style="list-style-type: none"> ● SHAFT OUTPUT - 65mm ROUND 	1							
90	21-2915	<ul style="list-style-type: none"> ● PLANET GEAR ASSEMBLY - 20T 2.25 MOD 	3						LOCTITE 277	
100	21-2906	<ul style="list-style-type: none"> ● OUTPUT - SUB-ASSEMBLY - X2000 / X2500 	1							
110	99-1103	<ul style="list-style-type: none"> ● TAPER BEARING 70mm (32014) 	2						LOCTITE 7471, 641	
120	21-2050	<ul style="list-style-type: none"> ● 3/8" BSP MAGNETIC PRESSURE PLUG 	2							
130	21-2026	<ul style="list-style-type: none"> ● OUTPUT HOUSING - SERIES 2 5.77:1 	1							
140	99-1504	<ul style="list-style-type: none"> ●○ OIL LIP SEAL - (100 x120 x12) 	1						LOCTITE 7471, 515 LOCTITE 209125 LOCTITE 243	See Seal Kit
150	21-3006	<ul style="list-style-type: none"> ● LOCKING NUT - M70 	1							
160	99-9213-012	<ul style="list-style-type: none"> ● SOCKET SET SCREW - M8 x 12 DOG POINT (14.9 Grade) 	2							
170	SK-21-290	<ul style="list-style-type: none"> ● SEAL KIT - GEARBOX - SERIES 2 - Comprising of items 20,50 &140 	1							
180	99-8101	<ul style="list-style-type: none"> ● GEAR OIL - EP320 - MINERAL (1 Litre Bottle) All units are supplied with 320 viscosity oil, except where the unit is to be or stored in extreme temperatures. 	1	400 ml required						
	99-8104	<ul style="list-style-type: none"> ● GEAR OIL - EP150 - MINERAL When using or storing the units below -15°C 								
	99-8106	<ul style="list-style-type: none"> ● GEAR OIL - EP460 - MINERAL When using or storing the units above 35°C 								

Ref. 15R-0002-1

X1500 Round Earth Drill - Parts List

From Serial Number 20012341

Ref. 15-0001-1

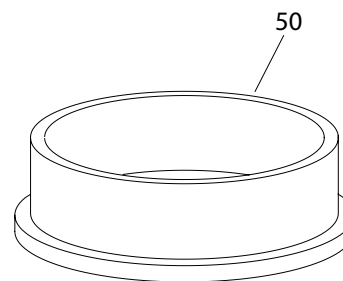
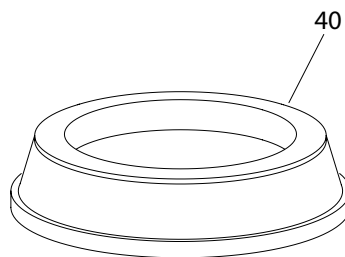
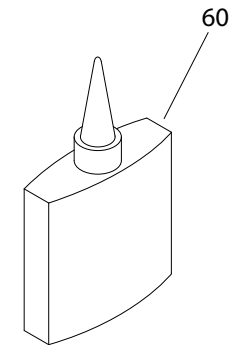
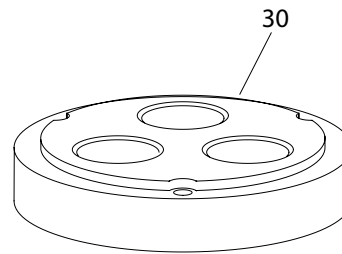
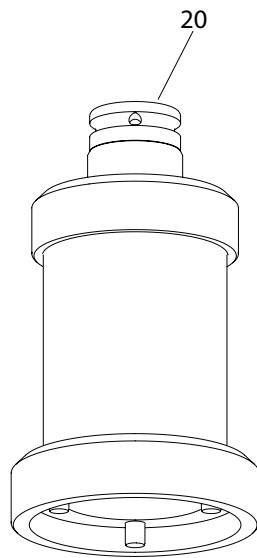
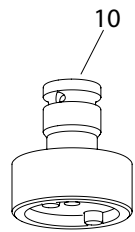

X1500 Round Earth Drill - Parts List



From Serial Number 20012341

ITEM	PART NO.	DESCRIPTION	QTY	TORQUE LOAD	THREAD TREATMENT	NOTES
10	TOOL - 1904	• PLANET POST TOOL	1			
20	TOOL - 1903	• LOCKING NUT TOOL	1			
30	TOOL - 1016	• RETAINING PLATE	1			
40	TOOL - 1019	• BEARING PRESS	1			
50	TOOL - 1135	• SEAL PRESS	1			
60	99-8217	• LOCTITE - 7471 ACTIVATOR	1			
	99-8205	• LOCTITE - 243 THREADLOCKER	1			
	99-8202	• LOCTITE - 515 FLANGE SEALANT	1			
	99-8206	• LOCTITE - 277 THREADLOCKER	1			
	99-8214	• LOCTITE - 641 BEARING RETAINER	1			
	99-8210	• LOCTITE - 209125 (BLUEMAX)	1			
	99-8218	• LOCTITE - 577 THREAD SEALANT	1			
						Ref. 15-0001-1

X1500 Round Earth Drill - Parts List

From Serial Number 20012341

Ref. 15-0002-1

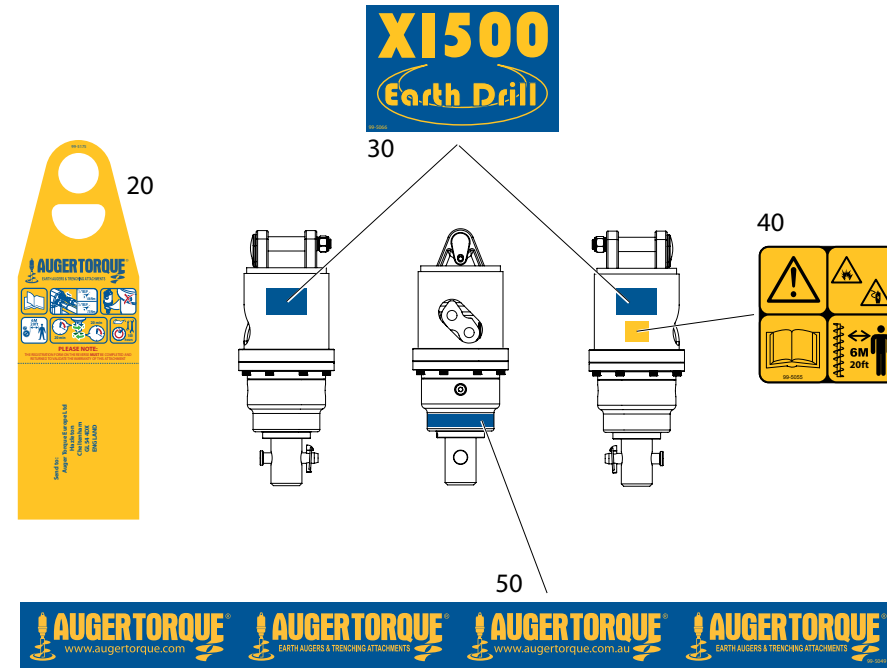
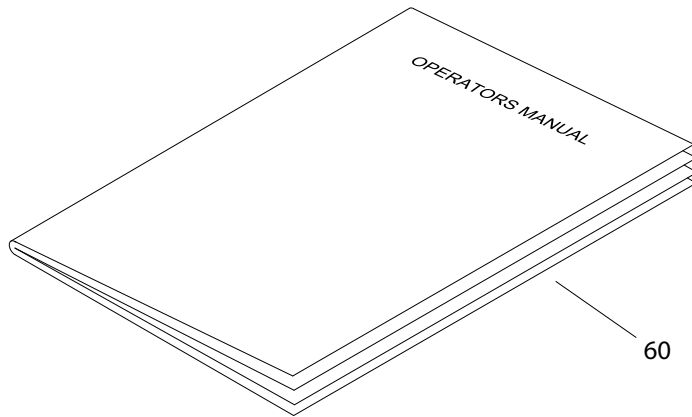
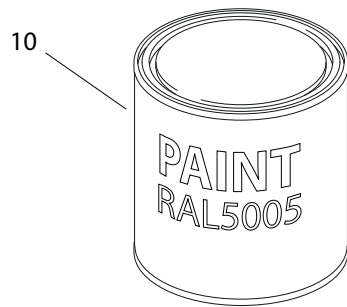

X1500 Round Earth Drill - Parts List



From Serial Number 20012341

ITEM	PART NO.	DESCRIPTION	QTY	TORQUE LOAD	THREAD TREATMENT	NOTES
10	99-8002	<ul style="list-style-type: none"> • PAINT - AUGER TORQUE BLUE 0.5L 	1			
20	99-5175	<ul style="list-style-type: none"> • REGISTRATION / INSTRUCTIONS TAG 	1			
30	99-5066	<ul style="list-style-type: none"> • LABEL - X1500 EARTH DRILL 	1			
40	99-5055	<ul style="list-style-type: none"> • LABEL - CAUTION 	1			
50	99-5049	<ul style="list-style-type: none"> • LABEL - AUGER TORQUE OUTPUT HOUSING 	1			
60	99-95-200001	<ul style="list-style-type: none"> • OPERATOR'S MANUAL - ENGLISH 	1			
	99-95-200002	<ul style="list-style-type: none"> • OPERATOR'S MANUAL - FRENCH 	1			
	99-95-200003	<ul style="list-style-type: none"> • OPERATOR'S MANUAL - FINNISH 	1			
	99-95-200004	<ul style="list-style-type: none"> • OPERATOR'S MANUAL - RUSSIAN 	1			
	99-95-200005	<ul style="list-style-type: none"> • OPERATOR'S MANUAL - GERMAN 	1			
	99-95-200006	<ul style="list-style-type: none"> • OPERATOR'S MANUAL - POLISH 	1			
	99-95-200007	<ul style="list-style-type: none"> • OPERATOR'S MANUAL - SPANISH 	1			
	99-95-200008	<ul style="list-style-type: none"> • OPERATOR'S MANUAL - DUTCH 	1			
	99-95-200009	<ul style="list-style-type: none"> • OPERATOR'S MANUAL - ARABIC 	1			
	99-95-200010	<ul style="list-style-type: none"> • OPERATOR'S MANUAL - DANISH 	1			

Ref. 15-0002-1

X1500 Round Earth Drill - Parts List

From Serial Number 20012341

Ref. 12-0004-1

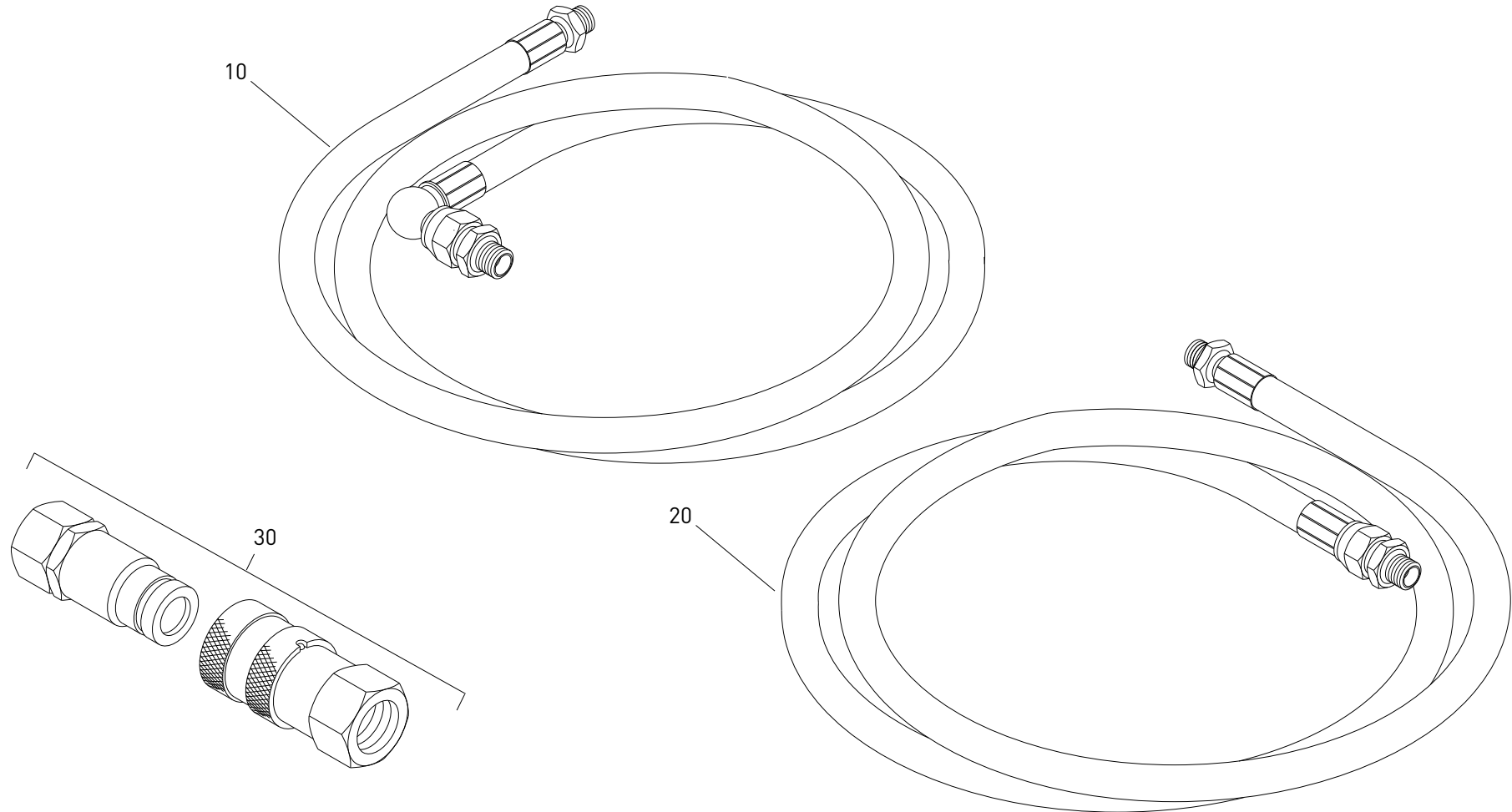

X1500 Round Earth Drill - Parts List



From Serial Number 20012341

ITEM	PART NO.	DESCRIPTION	QTY	TORQUE LOAD	THREADLOCKER	NOTES
10	99-7501	• HOSE - 1.4M 1/2" BSP 90°/Str	2			
	99-7503	• HOSE - 1.8M 1/2" BSP 90°/Str	2			
	99-7505	• HOSE - 2.2M 1/2" BSP 90°/Str	2			
20	99-7515	• HOSE - 1.4M 1/2" BSP Str/Str	2			
	99-7504	• HOSE - 1.8M 1/2" BSP Str/Str	2			
	99-7506	• HOSE - 2.2M 1/2" BSP Str/Str	2			
30	99-7052-M/F	• QRC'S - 1/2" FF	1			

Ref. 12-0004-1

X1500 Round Earth Drill - Parts List



From Serial Number 20012341

Auger Torque Publication Feedback Form

Please copy this form and when complete return to the address below

Your Contact Details

Please enter your feedback in the field below :-

Name :-

Address :-

Telephone :-

Email :-

Publication Number

Publication Title

Issue/Rev Number

Auger Torque Europe Ltd.
Hazleton
Cheltenham
England
GL54 4DX
Tel:+44 (0) 1451 861 652
Fax:+44 (0) 1451 861 652
www.augertorque.com